

# PNEUMATIC ACTUATOR AIR MOTOR

MODEL: 1701 - PA-6

Revision: 0

BULLETIN  
1701

## DESCRIPTION

Pneumatic Actuators are air motors designed to operate with 0 to 15 psig air pressure signals. These actuators are normally used with control instruments that supply air impulses between 3 psig and 15 psig to position the air motor.

Piston travel against a linear spring is directly proportional to impulse pressure changes over the entire range. The seal is a premolded roll type to fit the piston. This roll action provides a constant pressure area at all piston positions with minimum friction.

The seal is molded of Buna N synthetic rubber with nylon inserted fabric. It is a heavy-duty material with a 125 psig burst strength.

The actuator arm is connected direct to the piston plunger. This design eliminates cross shafts, friction and twisting stresses resulting in a very high available force to friction ratio.

The oil tempered spring position is preset at the factory for the 3 psig to 15 psig standard range. An adjustment nut is provided should changes be necessary.

The minimum stroke position is fixed by the top head. A maximum stroke adjustment is provided by the stem guide and lock nut.

The PA-6 Pneumatic Actuator is available with a Model VP Positioner when maximum accuracy of response to minute variations of impulse air is required. The Positioner functions as a pneumatic relay or booster pilot. It makes available the full supply line air pressure (usually 20 psig) for moving the piston, but limits this movement to the requirements of the instrument.

The Pneumatic Actuator is easily mounted on BV-CPAP and TBV-CPAP Butterfly Valves. The photograph below shows the compact assembly. The linkage shown provides for full adjustment.



PA-6 ACTUATOR

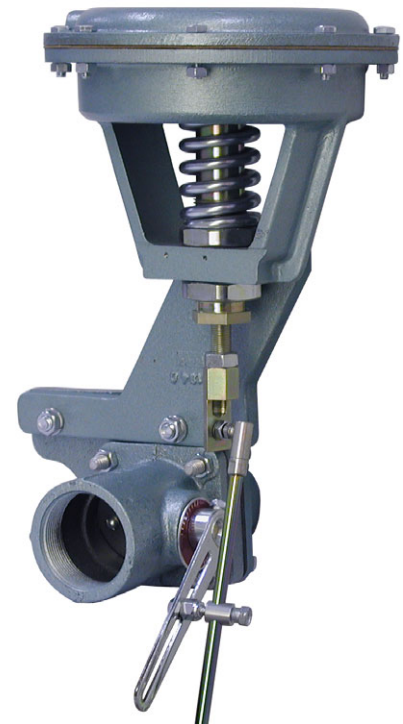

PA-6 ACTUATOR MOUNTED  
ON #20 BV BUTTERFLY VALVE

## PERFORMANCE SPECIFICATIONS

STROKE DISTANCE FULL TRAVEL	FORCE AVAILABLE IN POUNDS PER POUND OF SIGNAL CHANGE	
	Without Positioner	With Positioner
7/8"	25	190

CAUTION: Operation of combustion equipment can be hazardous resulting in bodily injury or equipment damage. Each burner should be supervised by a combustion safeguard and only qualified personnel should install, make system adjustments and perform any required service.



**pyronics inc.**

COMBUSTION FOR INDUSTRY

17700 MILES ROAD  
CLEVELAND, OH 44128  
www.pyronics.com

Tel: 216-662-8800  
Fax: 216-663-8954  
marketing@pyronics.com

NOTICE: PYRONICS practices a policy of continuous improvement in the design of its products. It reserves the right to change the specifications at any time without prior notice.

# PNEUMATIC ACTUATOR AIR MOTOR

BULLETIN 1701  
PAGE NO. 2

## DIMENSIONS

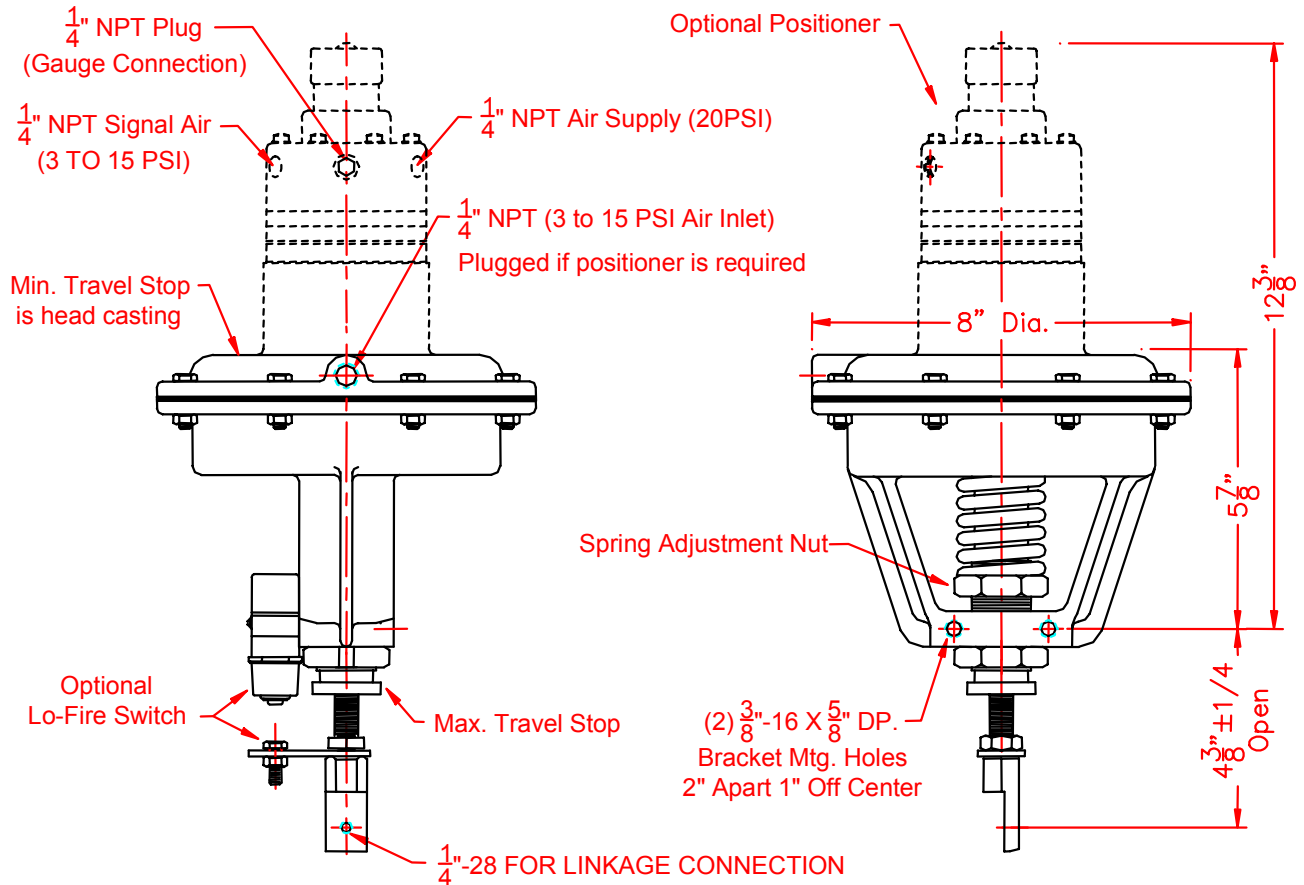

## OPERATION AND ADJUSTMENT

- 1) Mount Pneumatic Actuator on bracket furnished in any desired position.
- 2) The mounting bracket and/or arm may be reversed to give right-hand stroking.
- 3) Connect the linkage so that there is the least possible angular torque on the arm.
- 4) Make air connection to instrument with 1/4" tube or 1/4" pipe and test for leaks.
- 5) Set the linkage used for the stroke required, being sure actuator stops against the maximum and minimum stops and not on the linkage. The stroke distance is proportional between the two limits shown.
- 6) The spring setting, when shipped, covers a proportional band from 3 psig to 15 psig. The setting should not require field change.
- 7) Readjustment (if required)
  - a. With air pressure at exactly 3 psig or instrument minimum, rotate hex spring adjustment nut to set minimum piston position.
  - b. Check stroke range, starting at zero pressure and increasing slowly.
  - c. The piston should just move at 3 psig or instrument minimum.
  - d. Piston should stop moving at full stroked position at slightly over 15 psig (or instrument maximum).
  - e. Adjust maximum travel stop if necessary to achieve results in step (d) above.

## ORDERING INFORMATION

1. Specify quantity of PA-6 Pneumatic Actuators required.
2. Add catalog code letter VP for Positioner factory installed. (PA-6-VP)