



AIR PRESSURE SENSING SWITCH WITH ADJUSTABLE SET POINT

APPLICATION

Model RFS-4001 is a general purpose proving switch designed for HVAC and Energy Management applications. This switch can be used to sense positive, negative, or differential air pressure.

GENERAL DESCRIPTION & OPERATION

The plated housing contains a diaphragm, a calibration spring, a snap-acting switch and enclosure cover. The sample line connections located on each side of the diaphragm accept 0.25" metallic tubing via the integral compression ferrule and nut. Various electrical connections are available. An enclosure cover protects the operator from accidental contact. The enclosure cover accepts a 0.5" conduit connection.

MOUNTING (FIG. 1)

Select a mounting location which is free from vibration. The **Model RFS-4001** must be mounted with the diaphragm in any vertical plane in order to maintain the specified operating set point. Avoid mounting with the sample line connections in the "up" position.

The standard model is surface-mounted via the four 3/16" wide slots on the zinc-plated

Figure 1: Mount with the diaphragm in any vertical plane.

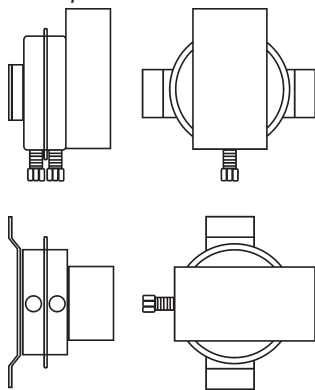

strap bracket. The mounting slots are 3-7/8" apart. Custom mounting configurations are available.

AIR SAMPLING CONNECTION (FIG. 2)

Model **RFS-4001** switches are equipped with sample line connections situated on either side of the diaphragm as shown in **Figure 2**. These connections are suitable for 1/4" OD metallic tubing. Locate the sampling probe a minimum of 1.5 duct diameters downstream from the air source. For sample lines up to 10 feet in length, 1/4" OD tubing is acceptable. For lines up to 20 feet, use 1/4" ID tubing. For lines up to 60 feet, use 1/2" ID tubing. Install the sampling probe as close to the center of the airstream as possible.

Refer to **Figure 2** to identify the **high pressure inlet (H)** and the **low pressure inlet (L)**. Select one of the five application options listed below, and connect the sample lines as recommended.

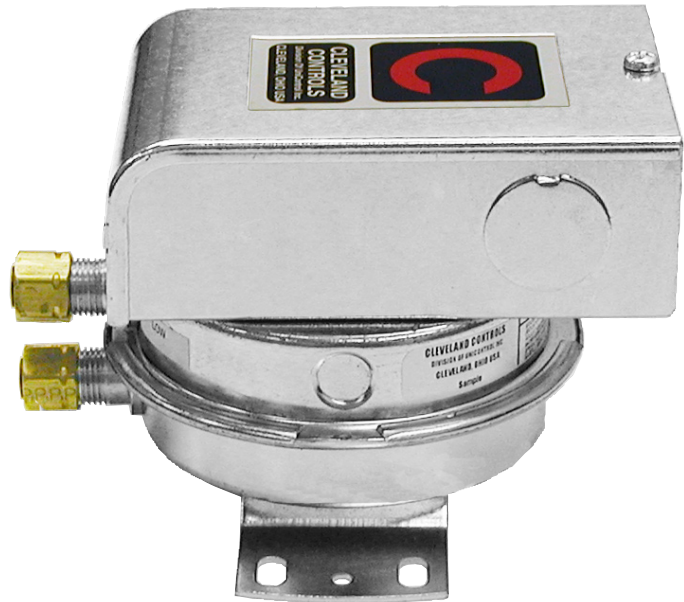
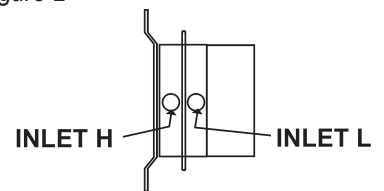
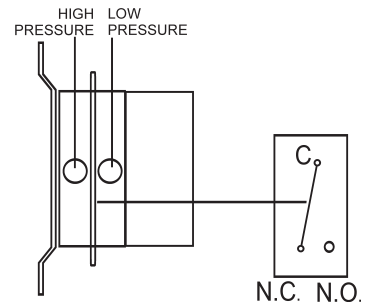

Figure 2



- | | |
|------------------------|------------------------|
| <i>Positive Only</i> | <i>Negative Only</i> |
| <i>Lower Negative</i> | <i>Higher Negative</i> |
| <i>Higher Positive</i> | <i>Lower Positive</i> |

Figure 3



The content on or accessible through CombustionDepot.com, (including, but not limited to) text, graphics and other materials, are provided by CombustionDepot.com, for informational purposes only. CombustionDepot.com does not claim ownership to any of the photos, images, or pictures of products on the site. These depictions are solely for information purposes and may not be an exact replication of the related product available for sale. All PDF and specification pages are gathered from the OEM web sites or publicly available information. CombustionDepot.com does not claim responsibility for any of the information found on these bulletins, documents, literature, specification charts, etc. and such information is subject to change without notice.



Positive Pressure Only: Connect the sample line to inlet **H**; inlet **L** remains open to the atmosphere.

Negative Pressure Only: Connect the sample line to inlet **L**; inlet **H** remains open to the atmosphere.

Two Negative Samples: Connect the higher negative sample to inlet **L**. Connect the lower negative sample to inlet **H**.

Two Positive Samples: Connect the higher positive sample to inlet **H**. Connect the lower positive sample to inlet **L**.

One Positive and One Negative Sample: Connect the positive sample to inlet **H**. Connect the negative sample to inlet **L**.

Figure 4

To prove excessive air flow or pressure:

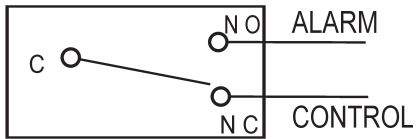

To prove insufficient air flow or pressure:

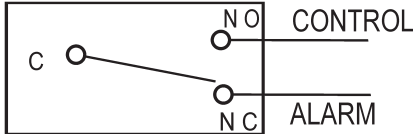

ELECTRICAL CONNECTIONS (FIGURES 3 & 4)

Before pressure is applied to the diaphragm, the switch contacts will be in the normally closed (NC) position. Wire control and alarm functions as shown in **Figure 4**.

FIELD ADJUSTMENT

The adjustment range of an **RFS-4001** Air Switch is 0.15 ± 0.02 " wc to 5.0"wc.

To adjust the set point, turn the adjusting screw counterclockwise until motion has stopped. Next, turn the adjusting screw 5 complete turns clockwise to engage the spring.

From this point, the next eight turns will be used for the actual calibration. **Each full turn represents approximately 0.61" wc.**

Please note: To properly calibrate an air switch, a digital manometer or other measuring device should be used to confirm the actual set point.

SPECIFICATIONS

MODEL RFS-4001

AIR PRESSURE SENSING SWITCH
WITH ADJUSTABLE SET POINT RANGE

Mounting Position:

Mount with the diaphragm in any vertical plane.

Standard Set Point Range:

- 0.15 ± 0.02 " wc to 5.0" wc.

Field Adjustable "Operate Range":

- 0.17" wc to 5.0" wc.

Field Adjustable "Release Range":

- 0.14" wc to 4.7" wc.

Approximate Switch Differential:

- Progressive, increasing from 0.05 ± 0.02 " wc at minimum set point to approximately 0.3" wc at maximum set point.

Measured Media:

Air or combustion by-products that will not degrade silicone.

Maximum Pressure:

$\frac{1}{2}$ psi (0.03 bar).

Operating Temperature Range:

-40 to 180F (-40.0 to 82.2C).

Life:

100,000 cycles minimum at $\frac{1}{2}$ psi maximum pressure each cycle and at maximum rated electrical load.

Electrical Rating:

300 VA pilot duty at 115 to 277 VAC;
15 amp noninductive to 277 VAC, 60 Hz.

Contact Arrangement:

- SPDT.

Electrical Connections:

- Screw terminals with cup washers.

Sample Line Connectors:

- Externally threaded $\frac{7}{16}$ " UNS 2A thread with nuts and self-aligning ferrules will accept 0.25"OD rigid tubing.

Approvals:

UL, CUL.

Shipping Weight:

14.1 oz.

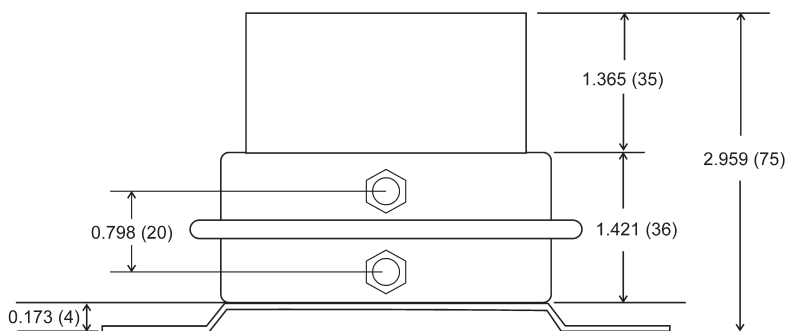
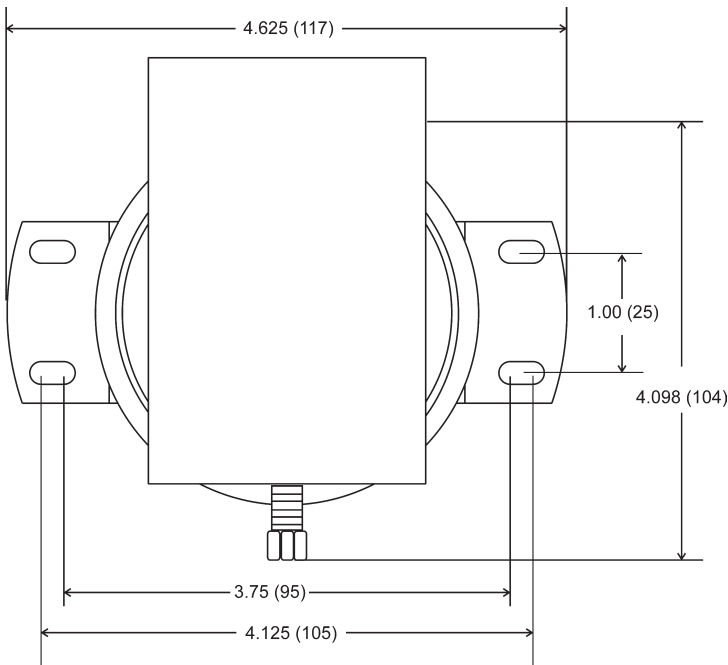

Reference Dimensions in Inches (Millimeters)