

ELECTRONIC FLAME SUPERVISION ULTRA VIOLET DETECTOR

MODEL: 7150 UV SCANNER

Revision: 0

DESCRIPTION

The 7150 Ultra Violet Detector is a photo-sensitive flame sensor for use with the Pyronics Sens-A-Flame II and flame monitoring system. The detector tube has a peak spectral response in the short wave ultra-violet region and, therefore, will not be activated by visible light, infra-red energy or sunlight, etc. The detector responds to the ultra-violet radiation generated by all flames.

The detector electronics have been designed to be compatible with the standard Sens-A-Flame II systems. The system may be used with either 7150, 7155 Detectors or Flame Rods without modification. Both Detectors and Flame Rods may be used intermixed on the same installation. Dual sensing means UV detectors and/or Flame Rods may be used on any flame input terminal.

SPECIFICATIONS

OUTPUT - Varies with flame condition :

Minimum : 1 micro Amp DC required for proper operation

Maximum : 100 micro Amps DC (Std.) 150 micro Amps DC (Hi-intensity)

MAXIMUM LEAD LENGTH : 200' under optimum conditions, see installation

AMBIENT TEMPERATURE : -4 to 140°F (-20 to 60°C)

CONNECTIONS :

Burner sighting : 1" NPT

Electrical connection : 1/2" flex conduit (Standard) 1/2" liquid-tight (Optional)

Wire : 36" stranded No. 18 AWG with 105°C insulation

AIR PURGE : 1/4" NPT

ENCLOSURE : Die-cast aluminum, sealed, weather resistant.
(Electronics assembly permanently mounted in enclosure)

FURNACE ATMOSPHERE SEAL :

Standard : 5 psig

Optional window : 25 psig

Optional lens : 25 psig

APPROVALS



U.L. Component recognized
File MH 8818



LR27844



For use with
Sens-A-Flame only



FEATURES

- Die cast Housing
- Weather Resistant
- Standard 5 PSIG Pressure seal
- Optional 25 PSIG Window or Lens
- Optional Integral Quartz Magnifying Lens
- 1" Sighting Connection for maximum aperture
- Provisions for air purge
- Hi-Intensity Model available

CAUTION: Operation of combustion equipment can be hazardous resulting in bodily injury or equipment damage. Each burner should be supervised by a combustion safeguard and only qualified personnel should install, make system adjustments and perform any required service.



ORDAN THERMAL PRODUCTS LTD

Combustion Equipment & Controls for Industry

21 Amber St # 9, Markham Ontario Canada L3R 4Z3

Tel: (905) 475-9292 Fax: (905) 475-3286

www.ordanthermal.com

ELECTRONIC FLAME SUPERVISION

BULLETIN
7150
PAGE NO.2

INSTALLATION

Locate the detector where the ambient temperature is between -4 and 140°F. Where the upper limit may be exceeded, use an air purge to keep the detector temperature below 140°F.

The detector will operate in any position, however, avoid positions where dirt and moisture may accumulate in the sighting port.

Wiring must conform with electrical codes, regulations, and ordinances. Use NEC Class 1 wiring. Type TW moisture-resistant wire is strongly recommended.

The Detector's supply wire (the white wire) must be connected to terminal "U" of a Pyronics Sens-A-Flame II. The Detector's signal wire (the black wire) must be connected to either terminal 10 on a single burner Sens-A-Flame II or a flame sensor terminal on a multiple burner Sens-A-Flame or Flame Monitor. DO NOT GROUND TERMINAL "U".

If terminal "U", or the UV, white wire does ground, damage to the Sens-A-Flame transformer will result.

To prevent damage, install a 1/8 Amp Slo-Blo fuse in-line with Terminal L1 of Sens-A-Flame II.

DO NOT RUN DETECTOR WIRES WITH LINE VOLTAGE OR IGNITION WIRES., isolate the UV black wire(s) from all other wires including the UV white wire(s). For multiple detector installations, it is recommended that single supply (white) wire be run from the Sens-A-Flame II terminal "U" to the detectors. Then supply each detector from the common supply (white) wire.

When the detectors are a long distance from the Sens-A-Flame II, using shielded wire with the shield grounded at the Sens-A-Flame II will improve the flame current signal quality. DO NOT PAIR THE SUPPLY (WHITE) AND SIGNAL (BLACK) WIRES IN THE SAME SHIELD AS LOSS OF SIGNAL OR INTERFERENCE MAY RESULT.

Ultra Violet radiation does not penetrate glass, moisture, oil, dust and dirt. therefore, clean the lens periodically or when detector signal strength weakens. An air purge can help maintain a clear sighting port.

CHECKOUT

CHECK ALL WIRING (see installation instructions above) Test to prove the detector can view only the burner being monitored, and not other sources of UV, such as ignition spark. Perform pilot turndown test for all pilot burners :

1. Adjust the pilot so that it may be viewed by the detector.
2. Verify that the pilot remains in full view for the full range of burner operation.
3. If a DC microammeter is available, measure the flame current signal generated by the detector over the full range of burner operation. For reliable operation, adjust the pilot to ensure a flame current signal in excess of 1 microampere at the maximum turndown position. NOTE : Current fluctuation is normal with Ultra Violet detection. The actual reading is an average. A heavily dampened meter will average readings and reduce fluctuation.
4. ENSURE THAT THE SMALLEST PILOT PROVEN BY THE SENS-A-FLAME II WILL RELIABLY IGNITE THE MAIN BURNER.

Interrupted Pilot :

The Main flame must be sighted by the detector when using interrupted pilots. A second detector must be used when the main flame is not visible through the pilot monitoring port.

Perform the safety shutdown test on all burners :

1. Place the system in operation for several minutes.
2. Manually shut off burner.
3. The Sens-A-Flame II "Flame On" light will go out, and terminals 3, 8, 13 and 14 will de-energize to shut down all valves.
4. Alarm terminal 4 should power.

Basic Operational Test :

1. Remove a detector from its burner port.
2. Put the Sens-A-Flame II into the "Purging" mode.
3. Put a match or other flame source in front of the detector. If the detector/wiring/combustion safeguard system is operating properly, the Sens-A-Flame II "Flame On" light will come on, and the "Purging:" cycle will be stopped.

NOTE : THIS TEST SHOULD ONLY BE PERFORMED WHEN THE SENS-A-FLAME II IS IN THE "PURGING" MODE.

ELECTRONIC FLAME SUPERVISION

BULLETIN
7150
PAGE NO.3

GENERAL DIMENSIONS AND ORDERING INFORMATION.

1. Specify Model No. & Quantity From Charts Below

DESCRIPTION	MODEL NUMBER	
	w/ 1/2" Flex Conduit Connector	w/1/2" Liquid Tight Fitting
Standard Detector Basic Assembly	7150-0100	7150-0101
Hi-Intensity Detector Basic Assembly	7150-0110	7150-0111
"A" Dimensions	1/2"	1"

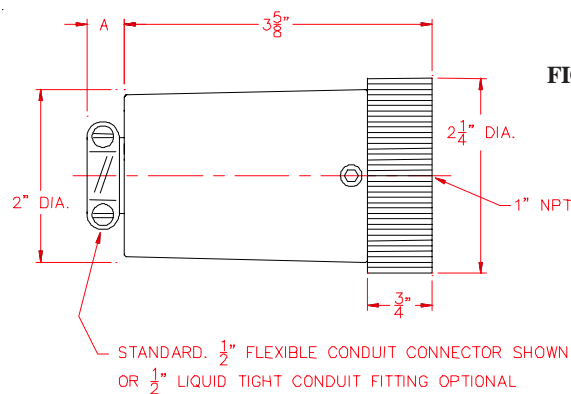

FIGURE 1

DESCRIPTION	MODEL NUMBER	
	w/ 1/2" Flex Conduit Connector	w/1/2" Liquid Tight Fitting
STANDARD DETECTOR		
w/ Air Purge Extension	7150-0200	7150-0201
w/ Quartz Window & Air Purge Extension	7150-0300	7150-0301
w/ Quartz Magnifying Lens & Air Purge Extension	7150-0400	7150-0401
HI-INTENSITY DETECTOR		
w/ Air Purge Extension	7150-0210	7150-0211
w/ Quartz Window & Air Purge Extension	7150-0310	7150-0311
w/ Quartz Magnifying Lens & Air Purge Extension	7150-0410	7150-0411
"A" Dimension	1/2"	1"

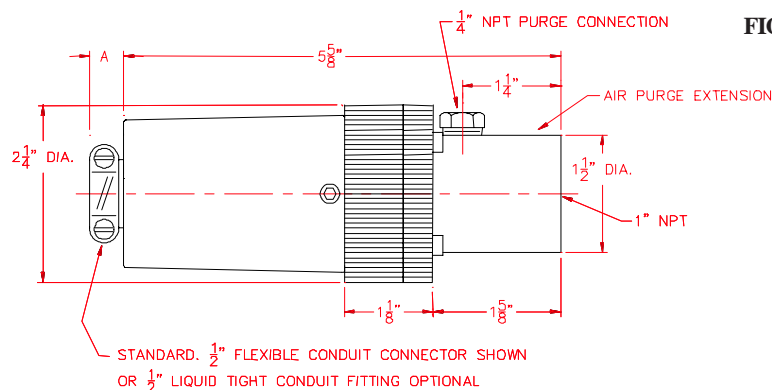
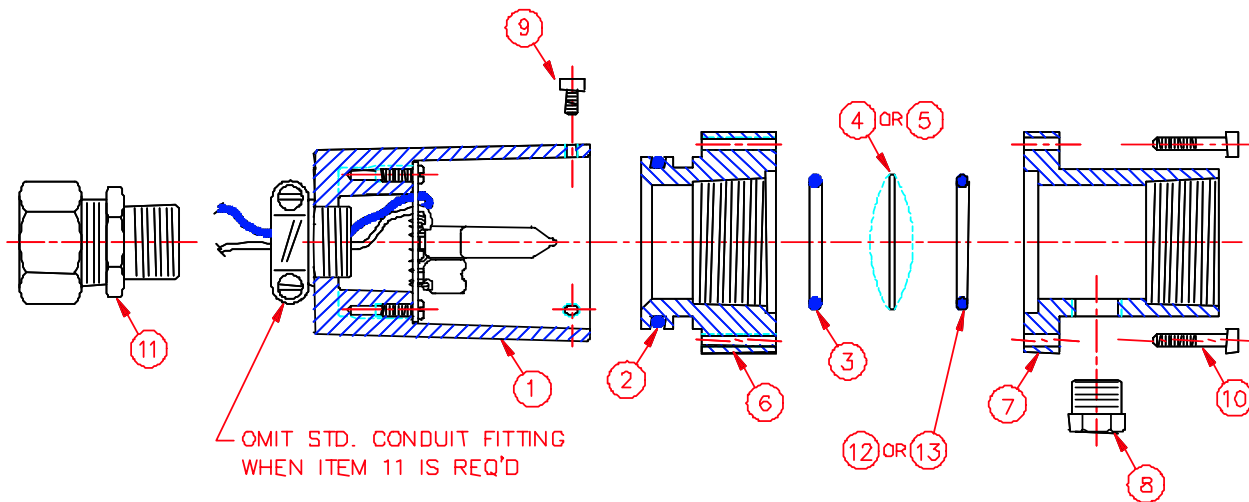

FIGURE 2

ELECTRONIC FLAME SUPERVISION

BULLETIN
7150
PAGE NO.4

DESCRIPTION AND PARTS LIST



Field Conversion Packages (Less Detectors)	
Description	Model Number
Air Purge Extension Package	7150-1005
Quartz Window w/ Air Purge Extension Package	7150-1006
Quartz Magnifying Lens w/ Air Purge Extension Package	7150-1007

ITEM	REQ'D	DESCRIPTION	Select Detector Model from Charts on page 3				Field Conversion Packages		
			7150-01XX	7150-02XX	7150-03XX	7150-04XX	7150-1005	7150-1006	7150-1007
			PARTS LIST						
1	1	Standard Body & Tube Assembly	7150-2001				—	—	—
		Hi-Intensity Body & Tube Assembly	7150-2000				—	—	—
2	1	O-Ring (Collar Seal)	7150-2002				—	—	—
3	1	O-Ring (AirPurge Extension Seal)	—	7150-2003			7150-2003	—	—
4	1	Quartz Window	—	—	7150-2004	—	—	7150-2004	
5	1	Quartz Magnifying Lens	—	—	—	7150-2005	—	—	7150-2005
6	1	Mounting Collar	7150-2006				—	—	—
7	1	Air Purge Extension (Quartz Holder)	—	7150-2007			7150-2007		
8	1	Air Purge Extension Plug	—	7150-2008			7150-2008		
9	3	Socket Hd. Screw (For Mounting Collar)	7150-2009				—	—	—
10	4	Socket Hd Screw (For Air Purge Extension)	—	7150-2010			7150-2010		
11	1	1/2" Liquid Tight Fitting (Optional)	7150-2011				—	—	—
12	1	O-Ring (Window Seal)	—	7150-2003		—	7150-2003		—
13	1	O-Ring (Magnifying Lens Seal)	—	—	—	7150-2012	—	—	7150-2012