

HIGH BLAST TORCHES

MODEL: 3245

REVISION 0

BULLETIN
3245

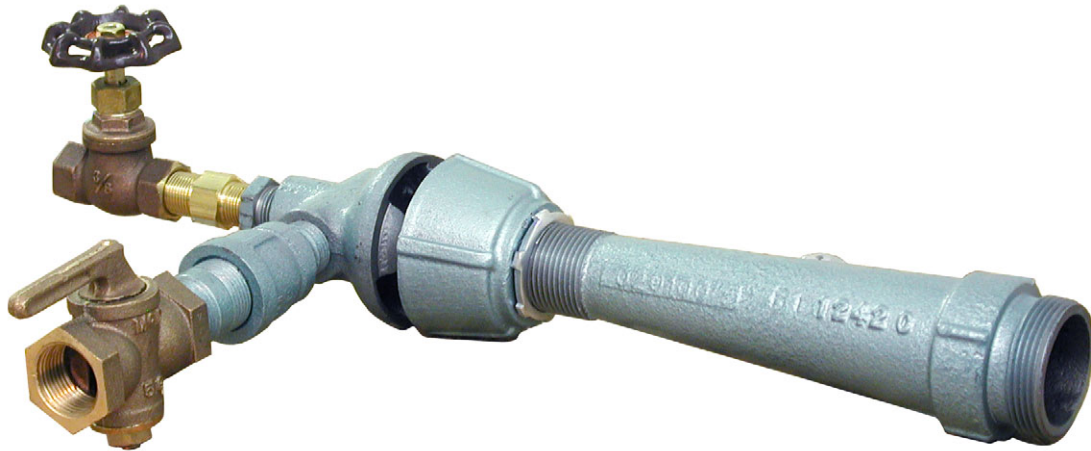

FEATURES

- Available in 8 sizes
- Blast torch flames
- High heat capacities - 40,000 to 3,000,000 BTU/HR
- Portable
- Air blower not required
- Available with cast iron standard or optional alloy steel nozzles
- Rugged heavy duty construction
- Compact trouble-free assembly
- Air and gas orifices easily removed for cleaning and inspection

USES

- Cupola lighting
- Direct flame mold drying
- Ladle heating
- Crucible preheating
- Pouring spout heating
- Die heating
- Soldering, brazing
- Welding preheating
- Flame heat treating & flame annealing
- Non ferrous metal melting
- Other spot heating applications

DESCRIPTION

High blast torches use a small amount of high pressure air to entrain incoming gas at the mixer. This produces a hard, sharp, clear blue, typical blast burner flame.

Only ten percent of the total air required is at 20 to 100 psi. This air is passed through a high pressure venturi which inspirates the gas flow and elevates its pressure.

The resultant mixture of one part air and one part gas is delivered to the main orifice at approximately 40% of the inlet air pressure.

The venturi efficiently entrains large quantities of combustion air and delivers the mixture to the burner nozzle. The high pressure air valve and primary air shutter provide for wide ranges of adjustment.

The design of high pressure injector stage prevents air feedback into the gas line. Capacities listed in the table on page 2 are for 90% primary air and may be increased where adequate secondary air is available.

CAUTION: Operation of combustion equipment can be hazardous resulting in bodily injury or equipment damage. Each burner should be supervised by a combustion safeguard and only qualified personnel should install, make system adjustments and perform any required service.



ORDAN THERMAL PRODUCTS LTD
Combustion Equipment & Controls for Industry
21 Amber St # 9, Markham Ontario Canada L3R 4Z3
Tel: (905) 475-9292 Fax: (905) 475-3286
www.ordanthermal.com

NOTICE: Pyronics practices a policy of continuous improvement in the design of its products. It reserves the right to change the specifications at any time without prior notice.

HIGH BLAST TORCHES

BULLETIN 3245
PAGE NO. 2

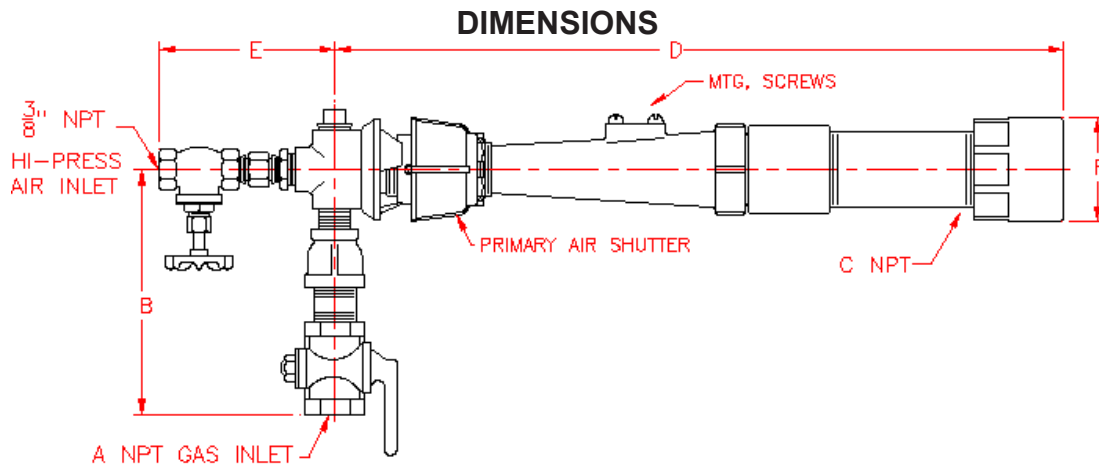

TORCH MODEL NUMBER	NAT. GAS CAPACITY IN CFH	CFM AIR 40 PSI	DIMENSIONS						FLAME LENGTH INCHES	SHIPPING WEIGHT
			ANPT	B	C NPT	D ± 1/4	E	F DIA		
6 HBT	55	1.2	1/2"	5-3/8"	3/4"	11-1/2"	4-1/8"	1-9/16"	10	5.0
8 HBT	90	2.4	1/2"	5-3/8"	1"	15-1/2"	4-1/8"	1-7/8"	12	6.5
10 HBT	205	5.5	3/4"	6-1/8"	1-1/4"	17-1/8"	4-3/8"	2-3/8"	15	9.5
12 HBT	320	7.3	3/4"	6-1/8"	1-1/2"	18-3/8"	4-3/8"	2-5/8"	18	10.3
16 HBT	565	10.0	1"	7-1/4"	2"	22-3/4"	4-7/8"	3-1/4"	24	20.0
20 HBT	770	13.8	1"	7-1/4"	2-1/2"	26-1/2"	4-7/8"	3-7/8"	30	25.0
24 HBT	960	17.3	1-1/4"	8-5/8"	3"	33-3/4"	5-1/8"	4-1/2"	36	40.0
32 HBT	1690	28.8	1-1/2"	9-3/4"	4"	41-1/4"	5-3/8"	5-7/8"	48	60.0

GAS CAPACITY AND AIR CFM MULTIPLIER TABLE

AIR PRESSURE	20	25	30	35	40	45	50	55	60	65	70	80	90	100
FACTOR	0.71	0.79	0.87	0.94	1.00	1.06	1.12	1.18	1.23	1.28	1.32	1.42	1.50	1.58

NOTE: Multiply gas and air capacities by factor for air pressure.

INSTALLATION

1. Make high pressure air and gas connections. These may be pipe or flexible hoses.
2. The connections should not be smaller than the valve sizes.
3. Minimum gas pressures: Manufactured 5" W.C., Mixed 3" W.C., Natural, Propane or Butane 1" W.C.
4. Mount the assembly using the mounting lug, if desired.
5. Check air and gas lines for leaks.

ADJUSTMENT

1. Loosen locknut on body and open primary air shutter wide.
2. Open air valve full.
3. Hold lighting torch alongside burner nozzle and slowly open gas cock.
4. After flame is lighted, flame character is adjusted by the setting of the gas cock.
5. Opening gas wider gives a softer, longer flame. Closing it slightly produces a sharper, shorter flame.
6. To shut off torch, close gas valve first and then air valve.

ORDERING INFORMATION

Please include the following information for each size High Blast Torch ordered:

1. Number required.
2. Specify "with alloy nozzles" if desired. Standard units are shipped with cast iron nozzles.
3. HBT assemblies include both air globe valve and gas cock. State if these are not required.
4. Kind of gas and available pressure.
5. Air pressure available.

If in doubt about High Blast Torch selection or use, send full details of the application so we can assist you.