

INFRA-RED BURNERS

MODEL: 3207

Revision: 0

BULLETIN
3207

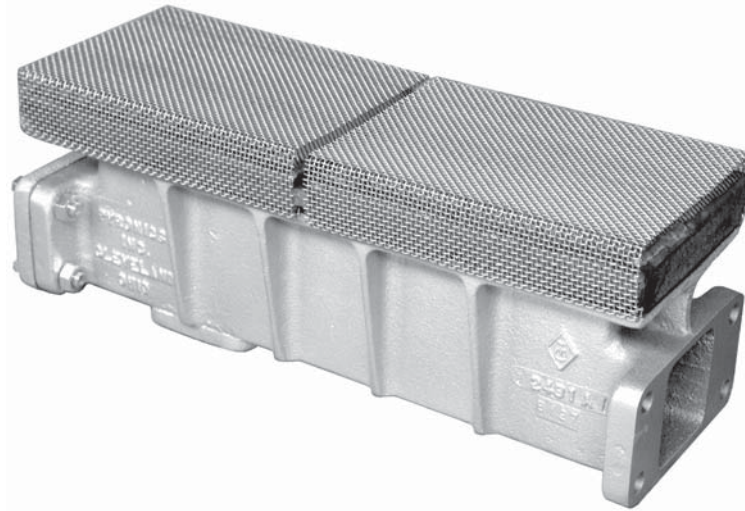

DESCRIPTION

The Infra-Red Burner is designed primarily for low temperature industrial process heating where heat transfer in the Infra-Red range is highly effective.

The entire top surface of each burner is an Infra-Red generator. Sections are easily coupled together to form continuous lines of radiating surface. Lines of burners may be grouped to form radiating panels of various sizes and shapes.

Flame travel from section to section and between lines is instantaneous so that single point ignition and flame failure protection may be applied.

Infra-Red Burners are designed to operate with completely aerated mixtures at pressures of 1/2" w. c. or higher.

Each section of Infra-Red Burner has two compartments. The lower chamber is the gas-air mixture feed manifold. Mixture pressures may range from 1/2" w. c. to 20" w. c.

The upper section of the Infra-Red generator has an expansion chamber, special burner-diffuser screen and radiating screen. Inconel wire is used in both screens for higher heat releases and long life. The two screens are fabricated into one easily removable assembly for cleaning or replacement.

The gas and air mixture burns between the two Inconel screens with the heat of combustion raising the temperature of the screens to the most effective radiating point.

Between the two chambers of each Infra-Red Burner is a simple, unique design metering orifice and mixture distributor. The adjustable distributor permits profile or contour heat patterns in any burner grouping.

USES

INFRA-RED BURNERS ARE APPLIED TO:

1. Paint and enamel drying.
2. Ink drying.
3. Drying porcelain frits on metals.
4. Over-glaze drying on bisque ware.
5. Core baking - particularly with resin binders.
6. Drying coatings on paper.
7. Railroad car thawing.
8. Die preheating.
9. Preheating of some metals.
10. Drying moving metal strips or sheets.
11. Textile drying, both yarn and woven cloth.
12. Heating plastics for lamination or forming.
13. Curing plastic and plastisole on metals.
14. Skin drying of foundry molds.
15. Other processes requiring temperatures up to 8000F.
16. Area heating.

CAUTION: Operation of combustion equipment can be hazardous resulting in bodily injury or equipment damage. Each burner should be supervised by a combustion safeguard and only qualified personnel should install, make system adjustments and perform any required service.



pyronics inc.

COMBUSTION FOR INDUSTRY

17700 MILES AVE.
CLEVELAND, OHIO 44128
www.pyronics.com

PHONE: (216) 662-8800
FAX: (216) 663-8954
marketing@pyronics.com

NOTICE: Pyronics practices a policy of continuous improvement in the design of its products. It reserves the right to change the specifications at any time without prior notice.

INFRA-RED BURNERS

WHAT IS INFRA-RED?

Infra-Red energy is electro-magnetic radiation, similar to radio waves, in the spectrum from the highest radar frequencies to visible light. Every object above absolute zero generates Infra-Red waves.

Radiant energy travels in the same manner as light waves and is reflected and refracted according to the laws of optics.

The radiant energy emitted by a surface depends on the nature of the surface and its temperature. At 600°F all radiation of a body is carried by wavelengths longer than visible red light. At 1300°F a body emits enough visible energy to be self-luminous and appears "red hot." Most of energy emitted is still carried by non-visible Infra-Red rays. At 1600°F less than 0.05% of the total energy is in the visible range.

Radiation differs from both convection and conduction in that the presence of matter (solid, liquid, or gas) is not required for radiant heat transfer. When a body absorbs radiation, its temperature rises. The medium through which radiant energy travels is not heated.

INDUSTRIAL INFRA-RED

Many materials used in industrial processes requiring temperatures up to 800°F will absorb heat from Infra-Red radiation sources faster than from convection or conduction sources. The quantity of radiant energy converted into heat depends upon the surface of the material and its reflection characteristics. With materials such as polished metals that are highly reflective, absorption of heat by the surface is slight and most of the radiated energy is wasted. On coated objects, the properties of the coating material play a major role in determining the behavior of the object subjected to radiation. If the coating is opaque to Infra-Red, all heat generation occurs near or at the surface and the metal underneath has little to do with the radiation absorbed.

In most industrial processes heat is applied to the surface of the object and is then transmitted through the object by conduction. The choice between convection and radiation for heating a surface should be based on the heat absorbing characteristics of the surface.

INFRA-RED ABSORPTION

All materials exhibit an ability to absorb more energy at some wavelengths of radiation than others. For most industrial heat processing operations, the wavelengths between 2 and 6 microns are most favorable.

For maximum heat transfer the Infra-Red generator should be operated so that most of its output energy will fall in the favorable absorption bands. At 1600°F face temperature, the IR series Infra-Red Burners have 92% of the total radiant energy above 2.0 microns.

With face temperatures of 1700°F and higher, more energy falls outside the preferred bands and efficiency of heat transfer is reduced.

APPLICATION OF INFRA-RED BURNERS

Infra-Red energy waves travel in straight lines from the source. Infra-Red Burners should be mounted so that nearly all energy radiated falls on the surfaces to be heated. The distance between the burners and the absorbing surface should be set to give the desired heat transfer per square foot per unit time with the radiant face at least 2" away. The total heat input required should be divided into enough sections to provide uniform heat transfer.

For those installations where some of the radiant energy will not fall on the work, wing type reflectors of polished aluminum or stainless steel should be installed so that all energy is directed to the work.

Infra-Red Burners will convert approximately 50% of their input energy into Infra-Red radiation. The balance of the input energy exists in hot flue gases. Drying operations particularly can use this additional convection energy to preheat, increase speeds and reduce heat losses from the work. An oven enclosure or hood will contain the flue gases and provide higher efficiencies. Normal venting practices should be followed for removal of flue gases after they have given up their energy to the work.

BURNER SELECTION

The ability of a material to absorb Infra-Red energy varies with its surface condition and the material itself. A measure of this ability is the emissivity or absorptivity (listed in standard handbooks) of the material at some preselected temperature.

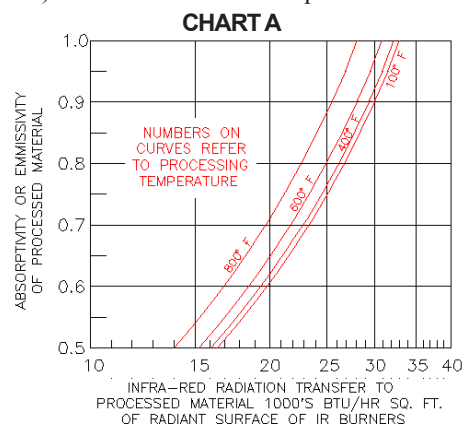

Chart "A" shows the Infra-Red transfer rates to be expected at various processing temperatures and absorptivity coefficients. The chart assumes that all of the Infra-Red energy available is directed to the work. The transfer rates should be modified directly by the estimated percentage of actual capture area of the work.

INFRA-RED BURNERS

The total heat required by the process should be divided by the modified transfer rate determined above to find the total Infra-Red Burner area for the installation.

EXAMPLE: Dry water from surface of pickled stainless steel strip 3 ft. wide. Water film .003" thick both sides. Strip moving at 100 feet per min. Absorptivities: water 0.963; stainless steel 0.15.

$$2 \times (0.003''/12'') \times 3' \times 100' \times 60 \times 62.5\#/cu. \text{ ft.} \times 1110 \text{ BTU/\#} \\ = 620,000 \text{ BTU/hr. to evaporate water.}$$

Since absorptivity of stainless steel is so low, little heat will be absorbed. Thus, it may be neglected in calculations.

Opposite 0.96 and 200°F line, read 31, 400 BTU/hr./sq. ft. of radiant surface. With Infra-Red Burners spaced 4" away from the moving sheet, a 80% view factor may be assumed.

Actual radiant transfer is then 31, 400 x 0.8 = 25, 200 BTU/hr./sq. ft. which is equal to 25 sq. ft. of Infra-Red Burner. One half or 12.5 sq. ft. should be installed on each side of the stainless steel strip.

BURNER DATA
(Select Sections to Match Total Area Required)

INFRA-RED BURNER CATALOG NUMBER	RADIANT SURFACE		BTU/HR INPUT PER SECTION
	WIDTH X LENGTH	SQ. FT. AREA	
46IR Straight	4" x 6"	1/6	10,000
412IR Straight	4" x 12"	1/3	20,000
412IRB-8 Bottom Inlet	4" x 12"	1/3	20,000
418IR	4" x 18"	1/2	30,000
412IRB-F Bottom Inlet Flanged	4" x 12"	1/3	20,000
418 IRB-8 Bottom Inlet	4" x 18"	1/2	30,000

NORMAL MIXTURE PRESSURE DEVELOPED AT VARIOUS AIR PRESSURES

AIR PRESSURE AT MIXER OUNCES/SQ. IN.	2	4	6	8	10	12	16
MIXTURE PRESSURE INCHES W. C.	1	2	3	4	5	6	8

MAXIMUM INLET FEED CAPACITIES
(Select Number of Inlets to Match Mixture Pressure and Total Area)

INLET CATALOG NUMBER & SIZE	SQUARE FEET OF RADIANT SURFACE AT VARIOUS MIXTURE PRESSURES IN INCHES W. C.					
	.5"	2"	4"	6"	8"	
IRP-3	0.2	0.3	0.4	0.5	0.7	End Plate with 3/8" NPT Tap
IRP-4	0.3	0.5	0.7	0.9	1.1	End Plate with 1/2" NPT Tap
IRP-6	0.5	1	1.3	1.6	1.9	End Plate with 3/4" NPT Tap
IRP-8	0.8	1.5	2	2.5	3	End Plate with 1" NPT Tap
IRF-16	3	6	8	10	12	Inlet Flange 2" NPT
IRP-B	-	-	-	-	-	Blank End Plate

NOTE: Each Burner Section, Flange, and Plate Includes Necessary Gaskets, Bolts, Nuts and Lockwashers for Assembly.

CAUTION: Operation of combustion equipment can be hazardous resulting in bodily injury or equipment damage. Each burner should be supervised by a combustion safeguard and only qualified personnel should install, make system adjustments and perform any required service.



pyronics inc.
COMBUSTION FOR INDUSTRY

17700 MILES AVE.
CLEVELAND, OHIO 44128
www.pyronics.com

PHONE: (216) 662-8800
FAX: (216) 663-8954
marketing@pyronics.com

NOTICE: Pyronics practices a policy of continuous improvement in the design of its products. It reserves the right to change the specifications at any time without prior notice.

INFRA-RED BURNERS

BULLETIN 3207
PAGE NO. 4

DIMENSIONS

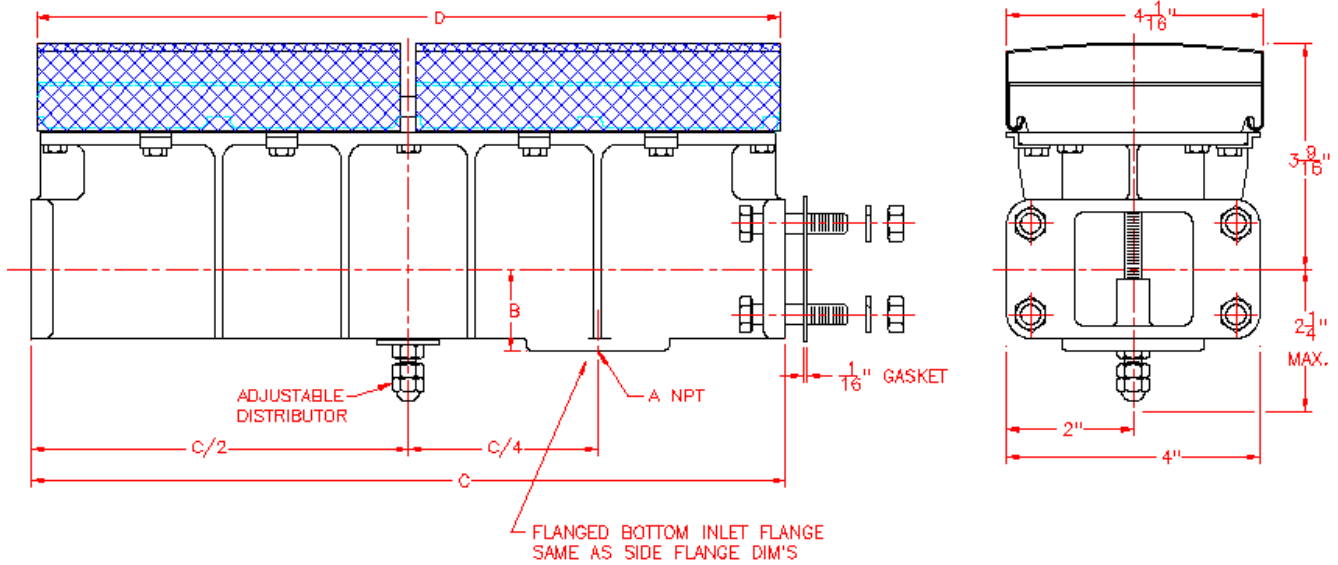

	Approx. Distributor Adjustment		
Mixture Pressure	46 IR	412 IR	418 IR
2" W. C.	2/3 turn	1-1/3 turn	2 turns
4" W. C.	1/4 turn	1/2 turn	1 turn
6" W. C.	1/6 turn	3/8 turn	3/4 turn
8" W. C.	1/8 turn	1/4 turn	5/8 turn

Model No.	A NPT	B	C	D
46 IR	---	---	6	5-3/4
412 IR	---	---	12	11-3/4
412 IR-8	1"	1-1/4"		
412 IR-F	---	1-3/16"		
418 IR	---	---	18	17-3/4
418 IR-8	1"	1-1/4"		

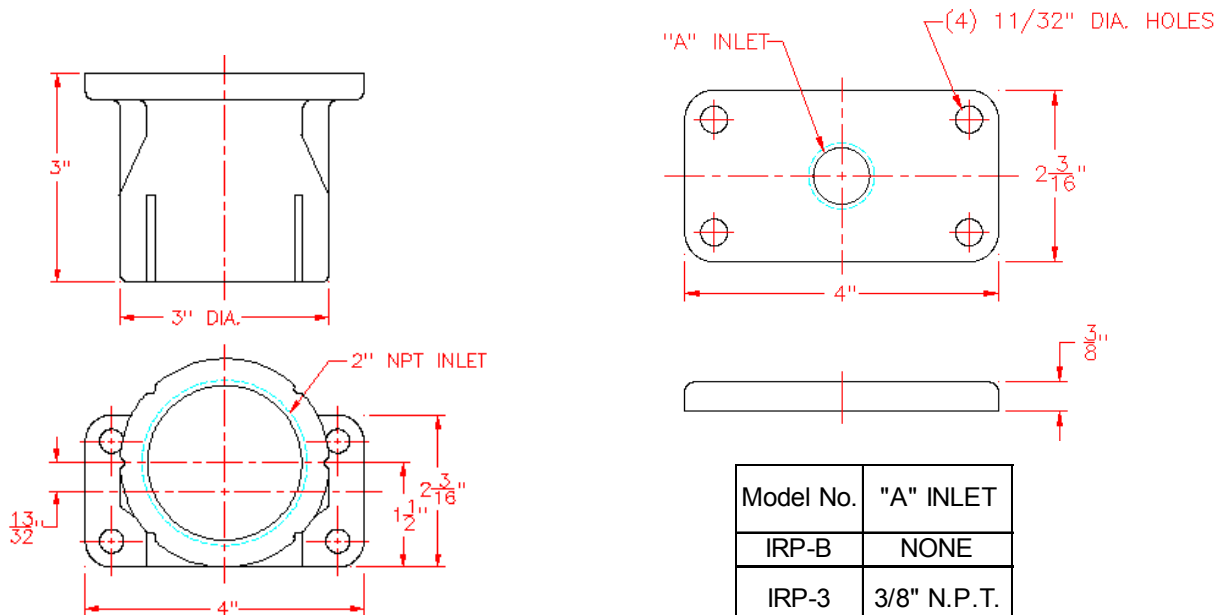

IRF-16

Model No.	"A" INLET
IRP-B	NONE
IRP-3	3/8" N.P.T.
IRP-4	1/2" N.P.T.
IRP-6	3/4" N.P.T.
IRP-8	1" N.P.T.

INFRA-RED BURNERS

BULLETIN 3207
PAGE NO. 5

IR OPTIONS

NOTE: SEE BULLETIN 3210 FOR IR REPAIR KITS

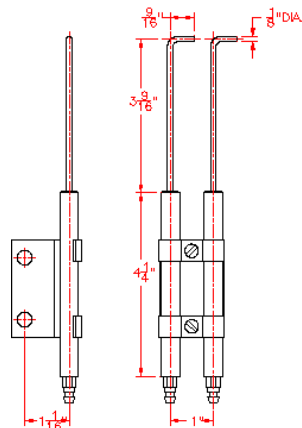

IREH-1984
ASSEMBLY AS SHIPPED

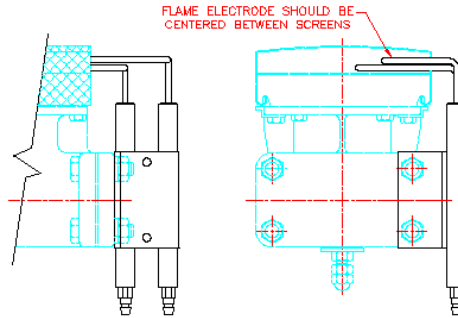

TYPICAL INSTALLATION
ELECTRODES TO BE
BENT & CUT BY CUSTOMER

NOTE ;

1. SAME ELECTRODE IS USED FOR SPARK OR FLAME ELECTRODE
2. WHEN USED ON SINGLE BURNER SPARK & FLAME ELECTRODES CAN BE MOUNTED ON ONE BRACKET AS SHOWN.
3. WHEN APPLIED TO A ROW OF BURNERS THE SPARK ELECTRODE WILL BE MOUNTED ON ONE END OF BURNER ROW AND THE FLAME ELECTRODE ON THE OPPOSITE END. EACH ELECTRODE REQUIRES AND USES THE SAME BRACKET.

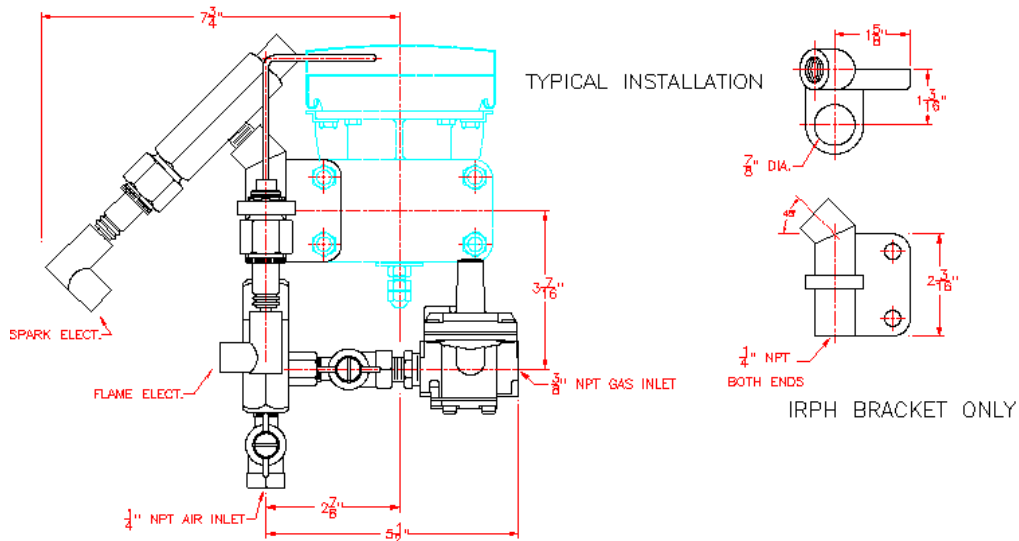

3276-2PBYS-F-IRPH

ORDERING INFORMATION

- | | |
|--|--|
| 1. Quantity and catalog number of sections required. | 1. Specify quantity of pilot brackets and #2 PBYS Pilots required. |
| 2. Specify mixture pressure to be used with burners. | 2. Catalog numbers of Mixers and Zero Governors. |
| 3. Quantity and catalog number of inlet pieces. | 3. Combustion Air Blower (voltage, phase, frequency). |
| 4. Quantity of #IRP Blank End Plates required. | 4. Specify other controls, etc. |

CAUTION: Operation of combustion equipment can be hazardous resulting in bodily injury or equipment damage. Each burner should be supervised by a combustion safeguard and only qualified personnel should install, make system adjustments and perform any required service.



pyronics inc.

COMBUSTION FOR INDUSTRY

17700 MILES AVE.
CLEVELAND, OHIO 44128

PHONE: (216) 662-8800
FAX: (216) 663-8954

**PYRONICS
INTERNATIONAL S.A.**

ZONING INDUSTRIEL, 4EME RUE
B-6040 JUMET BELGIUM
PHONE: (32) 71-256970
FAX: (32) 71-256979