

RADIANT LINE BURNERS RL-130-A

MODEL: 3208 RL-130

Revision: 0

BULLETIN
3208



FEATURES

- High Efficiency
- Low Operating Cost
- Easily Maintained
- High Turndown
- 2000°F Surface Temperature
- Superior Modular Design
- Withstands High Air Stream Velocities

APPLICATIONS

- Radiation/Convection Systems
- Process up to 1400°F
- Paint, Plastics, Porcelain Ovens
- Car Thawing
- Mold and Die Heating
- Textile and Paper Drying Systems
- Food Processing
- Core Drying

DESCRIPTION

The RL-130 Radiant Line Burner is designed for ease of installation. The radiation surface is entirely ceramic. No metal is exposed in the high temperature zone. It has a nominal rating of 25 - 30,000 BTU/HR with refractory temperatures up to 2000°F.

RL-130 burners use conventional gas/air mixing systems with air pressures in the 8 to 16 OSI range. Instant ignition and combustion stability is assured at all firing rates.

Spark and flame rod mountings are available to assure proper location and function.

The unique design permits a wide range of mounting patterns and manifolded arrangements. Adjustable metering orifices can be supplied for special manifolded contour heat patterns. The RL-130 burner is extremely flexible for all types of installations.

CAUTION: Operation of combustion equipment can be hazardous resulting in bodily injury or equipment damage. Each burner should be supervised by a combustion safeguard and only qualified personnel should install, make system adjustments and perform any required service.



pyronics inc.
COMBUSTION FOR INDUSTRY

17700 MILES AVE.
CLEVELAND, OHIO 44128
www.pyronics.com

PHONE: (216) 662-8800
FAX: (216) 663-8954
marketing@pyronics.com

NOTICE: Pyronics practices a policy of continuous improvement in the design of its products. It reserves the right to change the specifications at any time without prior notice.

RADIANT LINE BURNERS

RL-130-A

BULLETIN 3208
PAGE NO. 2

DESCRIPTION

The gas and air mixture burns in a unique combustion chamber within the RL-130 burner. Hot gases impinge on the ceramic ribs resulting in a uniform radiation pattern.

The RL-130 burner (radiating 3" wide x 12" long = 36 square inches) operates with a mixture pressure from 0.25" W.C. to 16" W.C.

A multiple orifice burner body uniformly distributes the

mixture to the ceramic face. Flame travel is instantaneous from orifice to orifice and from section to section.

RL-130 burners will perform best with 100% to 120% aeration, but other air-gas ratios can be used.

At normal mixture pressures combustion is very stable in air stream velocities up to 6000 f.p.m.

TYPICAL SYSTEM

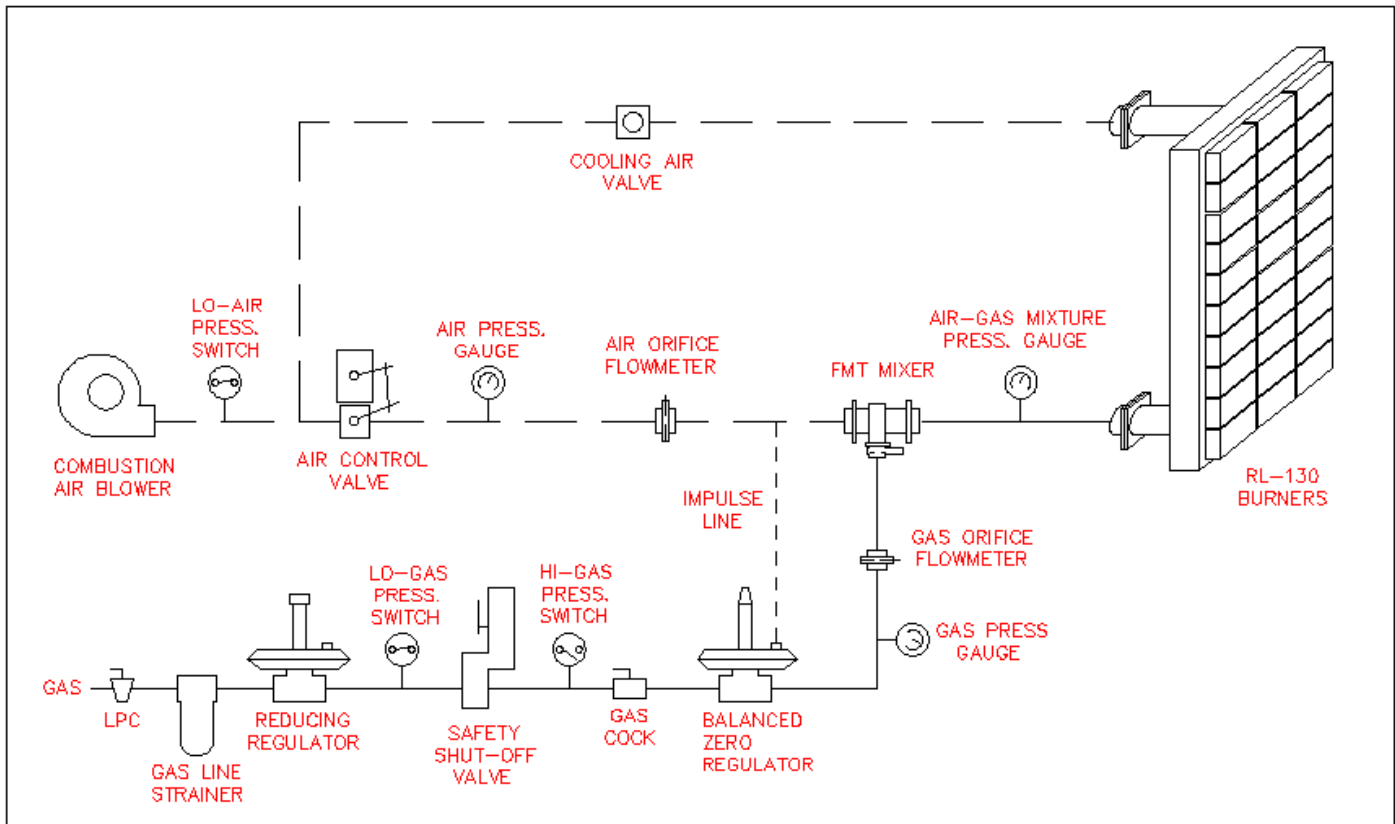

RADIANT LINE BURNERS RL-130-A

BULLETIN 3208
PAGE NO.3

CAPACITY TABLES

**TABLE I
CAPACITY AND SURFACE TEMPERATURE TABLE**

Mixture Pressure Inches W. C.	0.25	0.5	1	2	4	6	8	10	12	16
1000 BTU/HR. Per Burner	4.3	6	9	13	18	22	25	28	31	37
Refractory Temperatures (°F)	1240	1460	1590	1710	1830	1890	1940	1970	1950	1850

**TABLE II
MANIFOLD SELECTION - ALL GASES**

No. of Burners	Manifold Size*	No. of Burners	Manifold Size*	No. of Burners	Manifold Size*
1	3/4"	8	1-1/2"	24	2-1/2"
2	1"	10	1-1/2"	28	2-1/2"
3	1"	12	1-1/2"	36	3"
4	1"	14	2"	40	3"
5	1-1/4"	16	2"	44	3"
6	1-1/4"	20	2"	48	3"

* Manifold size indicated is nominal pipe size. If square tubing is used it should have at least the cross-section area of the manifold size recommended.

MOUNTING ARRANGEMENTS

MANIFOLD SIZE TO ACCOMODATE CAPACITY REQUIREMENTS ON ROUND
OR SQUARE MANIFOLDS.

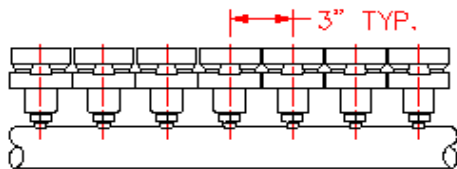

SIDE ELEVATION OF MANIFOLD
WITH BURNERS ON 3" CTRS.

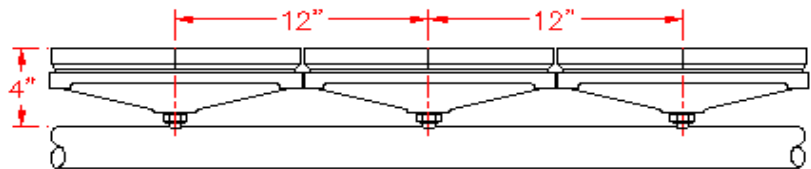

SIDE ELEVATION OF MANIFOLD
WITH BURNERS ON 12" CTRS.

CAUTION: Operation of combustion equipment can be hazardous resulting in bodily injury or equipment damage. Each burner should be supervised by a combustion safeguard and only qualified personnel should install, make system adjustments and perform any required service.



pyronics inc.
COMBUSTION FOR INDUSTRY

17700 MILES AVE.
CLEVELAND, OHIO 44128
www.pyronics.com

PHONE: (216) 662-8800
FAX: (216) 663-8954
marketing@pyronics.com

NOTICE: Pyronics practices a policy of continuous improvement in the design of its products. It reserves the right to change the specifications at any time without prior notice.

RADIANT LINE BURNERS RL-130-A

BULLETIN 3208
PAGE NO. 4

DIMENSIONS

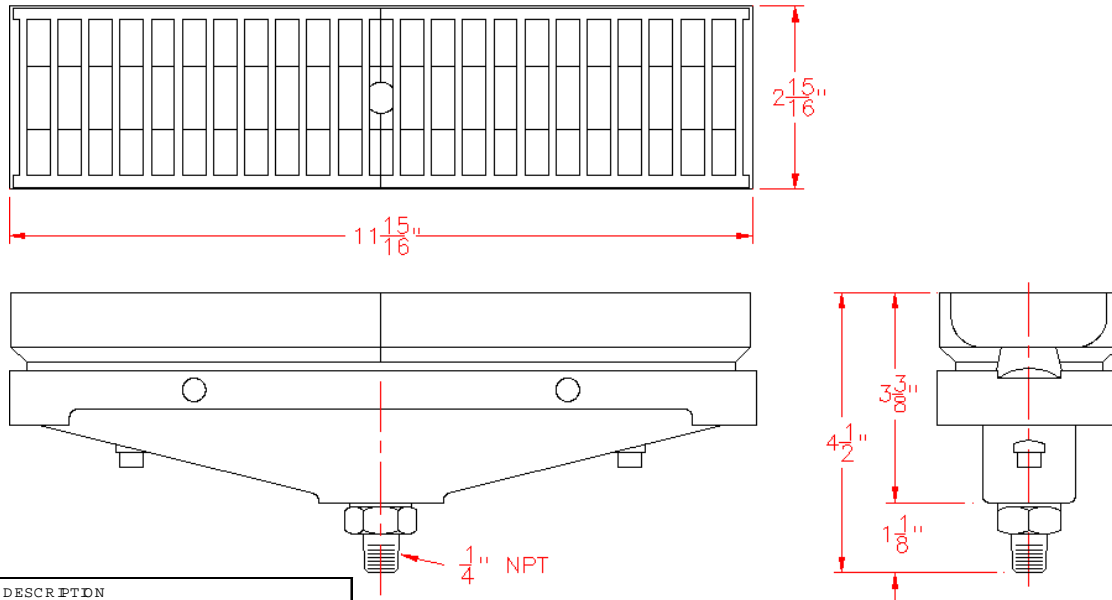

MODEL NO.	DESCRIPTION
RL-130-A	BURNER W /CASTBODY
RL-130-A-1S	BURNER W /CASTBODY & 1RAIL
RL-130-A-2S	BURNER W /CASTBODY & 2RAILS
RL-130-A-SE	BURNER W /CASTBODY & SE ASSY
RL-130-A-FE	BURNER W /CASTBODY & FE ASSY
RL-130-A-B	BURNER W /CASTBODY & PLOT BRKT
XRL-130-A	BURNER W /CASTBODY CLOSED ENDS
RL-RK	REPAIR KIT W /OPEN ENDS
XRL-RK	REPAIR KIT W /CLOSED ENDS
RL-AS-A	STEEL BURNER BODY
RL-A-A	CAST IRON BURNER BODY
RL-B	BLANKET
RL-C	6" CERAMIC HEAD
RL-D	2 RAILS
RL-F	ORFICE PLATE
RL-E	ORFICE
RL-G	SOCKET SET SCREW
RL-S2	2 ALLOY RAILS WITH SCREWS (NOT SHOWN)
RL-RK	INSERT PAD REGDZER (PNT)
RL-130-AS	BURNER W /STEELBODY
RL-130-AS-1S	BURNER W /STEELBODY & 1RAIL
RL-130-AS-2S	BURNER W /STEELBODY & 2RAILS
RL-130-AS-SE	BURNER W /STEELBODY & SE ASSY
RL-130-AS-FE	BURNER W /STEELBODY & FE ASSY
RL-130-AS-B	BURNER W /STEELBODY & PLOT BRKT
XRL-130-AS	BURNER W /STEELBODY CLOSED ENDS

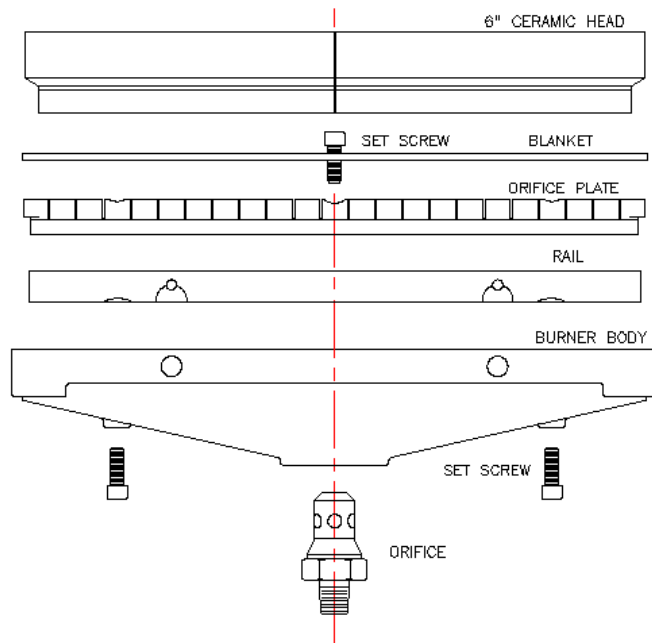

ORDERING INFORMATION

1. Number and type of burners required.
2. Type ignition and flame protection assembly.