

BURNERS INFRA-RED CERAMIC

MODEL: 3209-IRC

Revision: 0

BULLETIN
3209

DESCRIPTION

The IRC-1 Infra-Red Ceramic Burners are designed to deliver high intensity radiation. The radiation surface is entirely ceramic. No metal parts are exposed in the radiation zone.

IRC-1 Burners utilize most clean gaseous fuels with conventional mixing systems in the 8-16 ounce air pressure range.

Spark and flame rod mountings are available to insure positive ignition and flame supervision.

The IRC-1 Burners are applicable to many types of heat processes. The simple, flexible design lends itself to a wide range of mounting and manifolding patterns.

Individual adjusting valves are available for special heat patterns.



APPLICATIONS

- Ceramic tile curing and glazing
- Core drying
- Radiation convection systems
- Food processing
- Textile ovens
- Paint, plastics drying & curing
- Glass heat treating & polishing
- Mold & die heating
- Paper drying
- Plastic vacuum forming
- Metal heat treating

FEATURES

- High efficiency
- Simple modular design
- All ceramic face
- Rugged cast iron body
- Easy maintenance
- Stable flame in high drafts
- High turn down
- 2000°F surface temperature
- Flexible mounting patterns

CAPACITY TABLE

Mixture Pressure - Inches W. C.	0.25	0.5	1	2	4	6	8	10	12
1000 BTU/Hr. Per Burner*	4.3	6.7	10.3	15.4	22	27.4	32.3	36.8	39.3
Surface Temperature - °F	1350	1450	1550	1700	1830	1900	1900	1940	1950

* BASED ON 100% AERATION

CAUTION: Operation of combustion equipment can be hazardous resulting in bodily injury or equipment damage. Each burner should be supervised by a combustion safeguard and only qualified personnel should install, make system adjustments and perform any required service.



pyronics inc.

COMBUSTION FOR INDUSTRY

17700 MILES AVE.
CLEVELAND, OHIO 44128
www.pyronics.com

PHONE: (216) 662-8800
FAX: (216) 663-8954
marketing@pyronics.com

NOTICE: Pyronics practices a policy of continuous improvement in the design of its products. It reserves the right to change the specifications at any time without prior notice.

BURNERS INFRA-RED CERAMIC

BULLETIN 3209
PAGE NO. 2

GENERAL DIMENSIONS

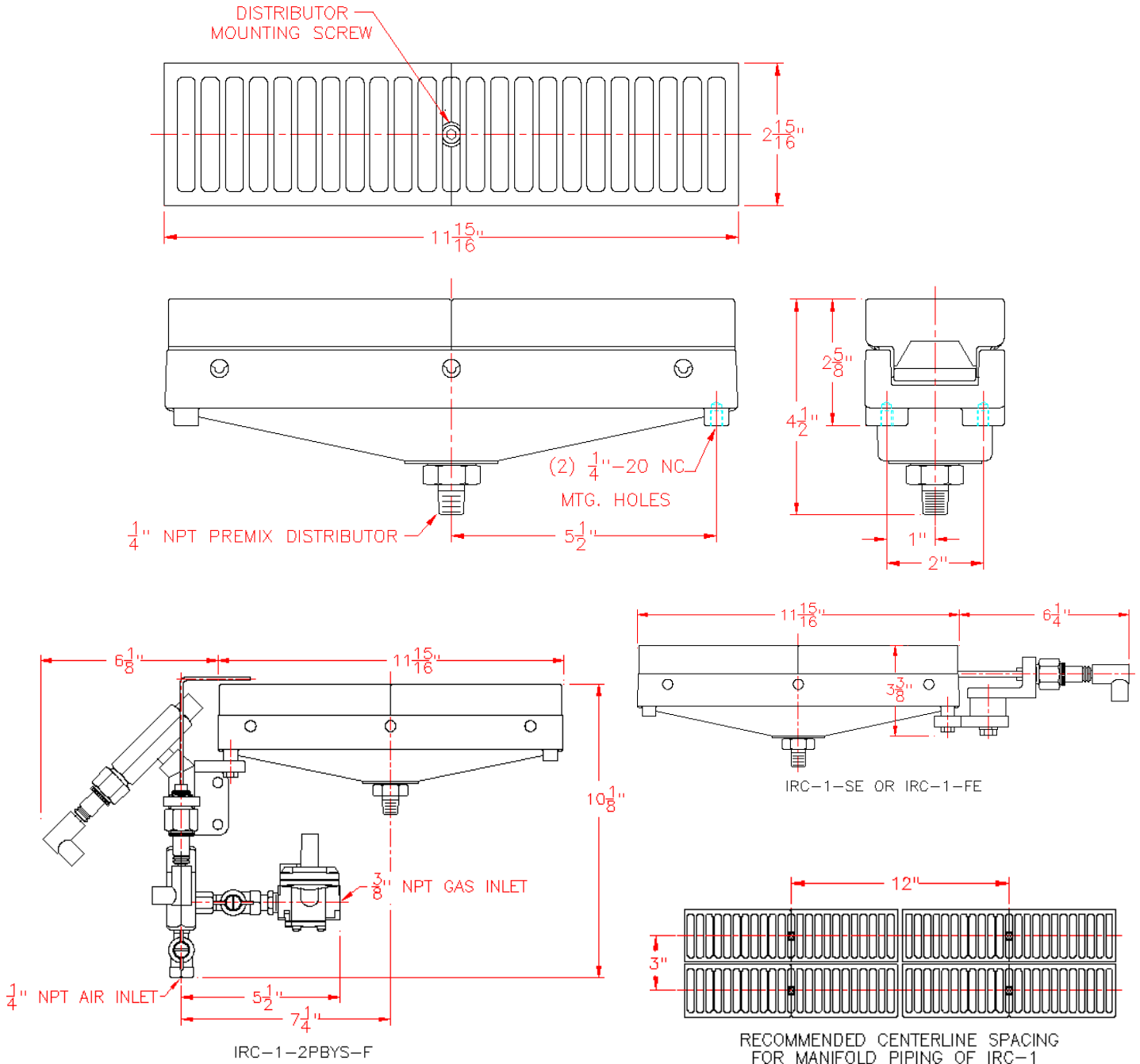

ORDERING INFORMATION

1. Number of Burners
2. Type of Manifolding, if any.
3. Type of Gas to be used.
4. Pilot or Direct Spark Ignition.
5. Type of Flame Supervision.