

# REPAIR KIT IR BURNERS

MODEL: 3210 - IR - SA

Revision: 0

BULLETIN  
3210

## INFRA-RED SCREEN REPLACEMENT INSTRUCTIONS

1. Remove old screen assembly and discard.
  2. Clean top surface of burner casting. Use file and/or scraper. Be sure that inside of burner casting is also clean.
  3. Slide outer guard screens from casting and dispose of cardboard shipping inserts.
  4. Squeeze a 1/8" wide continuous bead of "Pyroseal" liquid gasket from tube around top flange of burner. Place bead between screen mounting holes and edge of body cavity. (See Figure 1.) Caution: Do not leave any gaps in the bead of liquid gasket. Liquid gasket dries rapidly. Work with one burner at a time.
  5. Position new cast screen assembly on burner casting. Be careful not to damage or puncture screen. Line up all holes and start bolts in locations without clips.
  6. Install guard screen clips under bolts in locations shown in Fig. 2 only and tighten all bolts uniformly.
- \*Burners shown viewed from the bottom.
8. Slide new outerguard screens in place and lock in position by crimping in notched openings as shown in Fig. 3. Tap clips against outerguard screens with hammer.
  9. Burner is now ready for service.

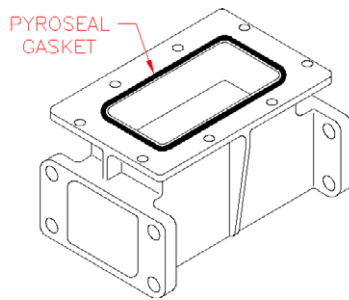
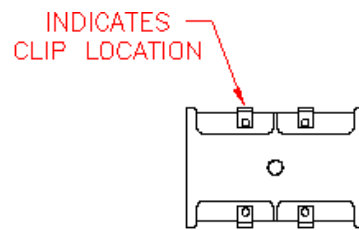
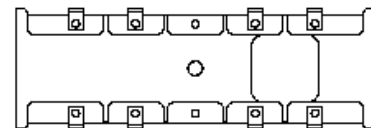

FIGURE 1



\* 46 IR BURNER



\* 412 IR BURNER

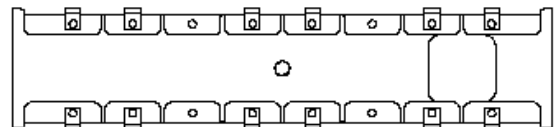

\* 418 IR BURNER

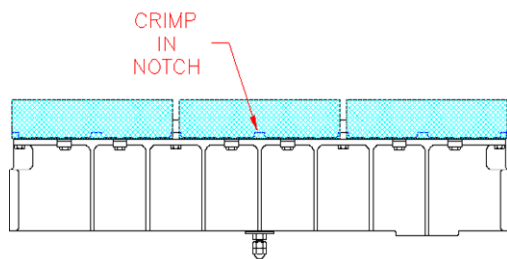

FIGURE 3

### EACH REPAIR KIT CONTAINS:

- Burner Frame Assembly
- Guard Screens
- Screen Clips
- Screws
- Pyroseal Liquid Gasket

### \*\*CAUTION\*\*

SCREEN TEMPERATURE SHOULD NOT EXCEED 1500°F

Model Number	Weight in Pounds
3210-46 IR-SA	3.5
3210-412 IR-SA	6.5
3210-418 IR-SA	8

CAUTION: Operation of combustion equipment can be hazardous resulting in bodily injury or equipment damage. Each burner should be supervised by a combustion safeguard and only qualified personnel should install, make system adjustments and perform any required service.



**pyronics inc.**

COMBUSTION FOR INDUSTRY

17700 MILES AVE.  
CLEVELAND, OHIO 44128  
www.pyronics.com

PHONE: (216) 662-8800  
FAX: (216) 663-8954  
marketing@pyronics.com

NOTICE: Pyronics practices a policy of continuous improvement in the design of its products. It reserves the right to change the specifications at any time without prior notice.