

BLAST PILOT TYPE PB AND PBS

MODEL: 3280, 3281

Revision: 0

BULLETIN
3280, 3281



FEATURES

1. Mixer enclosed-no dirt, thus no mixture change.
2. High mixture pressure-correct burner design-stable flame.
3. Flame can be positively directed and direction maintained.
4. Can be modified to pilot all types of burners.
5. Same flame characteristics regardless of atmospheric conditions.
6. Adaptable to automatic ignition in combination with flame failure equipment.
7. Made in five sizes. Capacities from 10,000 BTU to 80,000 with 1 lb. air.
8. Constant gas-air ratio maintained over wide range of operation.
9. Can be used with any kind of gas.
10. Easily ignited by any means at hand.
11. Simple and easy to install.

DESCRIPTION

The "PB" Assembly consists of a blast burner tip, gas-air Midget Mixer, zero governor, combination ratio and shut-off gas cock, air cock and the necessary pipe fittings, assembled as shown. The "PBS" Assembly includes a special tip with spark plug for automatic ignition. Customer must furnish suitable transformer, push button and necessary wire and cable.

CAPACITY TABLE

Catalog No.	Blast Tip Size	Burner Port Area	Capacities in 100 BTU's for Various Air Pressures			
			4 oz.	8 oz.	16 oz.	32 oz.
1-PB or PBS	1BT or 1 BTS 1/8"	0.0264	4	6	9	12
2-PB or PBS	2BT or 2BTS 1/4"	0.0513	9	13	18	25
3-PB or PBS	3BT or 3BTS 3/8"	0.0671	12	16	23	32
4-PB or PBS	4 BT or 4BTS 1/2"	0.0971	18	25	35	48
6-PB or PBS	6FR or 6FRS 3/4"	0.182	37	52	74	-

Midget Mixer capacities same as above when used with equivalent burner areas.

CAUTION: Operation of combustion equipment can be hazardous resulting in bodily injury or equipment damage. Each burner should be supervised by a combustion safeguard and only qualified personnel should install, make system adjustments and perform any required service.



pyronics inc.
COMBUSTION FOR INDUSTRY

17700 MILES AVE.
CLEVELAND, OHIO 44128
www.pyronics.com

PHONE: (216) 662-8800
FAX: (216) 663-8954
marketing@pyronics.com

NOTICE: Pyronics practices a policy of continuous improvement in the design of its products. It reserves the right to change the specifications at any time without prior notice.

BLAST PILOT TYPE PB AND PBS

BULLETIN 3280, 3281
PAGE NO. 2

APPLICATION

The "PB" Assembly, is a small, compact, package unit specially designed for piloting all types of blast and gun-type burners. The flame on this pilot will not blow off even when operating against high furnace back pressures or under excessive draft conditions.

These Blast Pilots also have many uses as small burners when used either singly or in groups. Small single burner applications such as torch soldering, glass working, tube bending, spot annealing, hardening and pre-heating can be easily handled with this assembly. Any experienced application engineer will find many uses for this assembly or modifications of it.

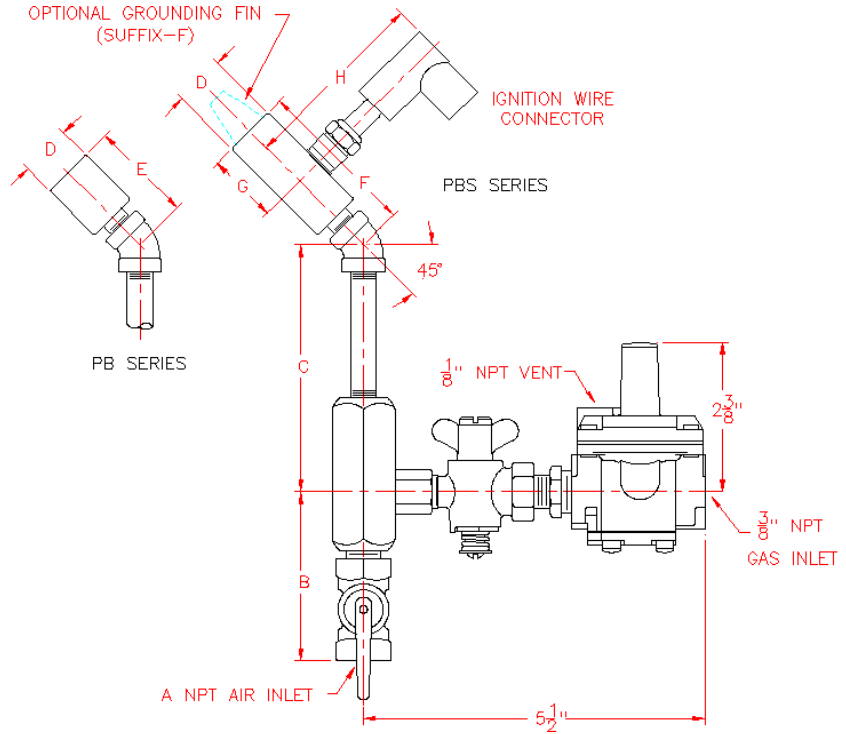

DIMENSION TABLE FOR BLAST PILOT ASSEMBLY

Model No.		A NPT	B	C	D DIA	E	F	G	H
Less Spark	With Spark								
1PB	1PBS	1/4	2-5/8	4	13/16	1-5/8	2-1/2	1-1/8	3
2PB	2PBS	1/4	2-5/8	4-7/8	1	2	3	1-1/4	3-1/8
3PB	3PBS	3/8	2-7/8	5-1/4	1-1/4	2-1/4	3-3/8	1-3/8	3-1/4
4PB	4PBS	1/2	3-1/2	6-1/2	1-3/8	2-1/2	3-3/4	1-1/2	3-3/8
6PB	6PBS	3/4	4-1/2	6-3/4	1-9/16	2-7/8	2-7/8	3/8	3-3/8

Note: All dimensions are in inches ± 1/8. 1-4PB use BT Blast Tip, 6PB uses FR Nozzle.

ORDERING INFORMATION

1. Number of Blast Pilot Assemblies required.
2. Catalog Number of each.
3. Shipping instructions.

If you are in doubt as to size or use, send full information regarding type of burner you wish to pilot, or a description of the special application under consideration.