

# COIL CAGES

MODEL: CC SERIES

Revision: 0

BULLETIN  
3231

Coil Cages less burner assemblies may be purchased separately. When the coil pipe does not extend beyond the tank wall the Coil Cage\* may be attached by using four flange lugs held in place by bolts welded to the tank. Specify "flange mounting" when ordering. Pilot bracket is not included with Coil Cage although mounting holes are drilled and tapped in all cages.

\* The 641CC and 642CC Coil Cages have no mounting flange.

CATALOG NUMBER	WILL FIT IMMERSION COIL PIPE SIZES	WILL HOLD AN OR FR BURNER NOZZLE	
		CATALOG NO's	PIPE SIZES
20CC	2-1/2 - 2"	#8 AND #10	1" AND 1-1/4"
24CC	3" - 2-1/2"	#10 AND #12	1-1/4" AND 1-1/2"
32CC	4" - 3"	#12 AND #16	1-1/2" AND 2"
481CC	6" - 5"	#12 AND #16	1-1/2" AND 2"
482CC	6" - 5"	#20 AND #24	2-1/2" AND 3"
641CC	8"	24FR	3"
642CC	8"	32AN	4"

## DIMENSIONS

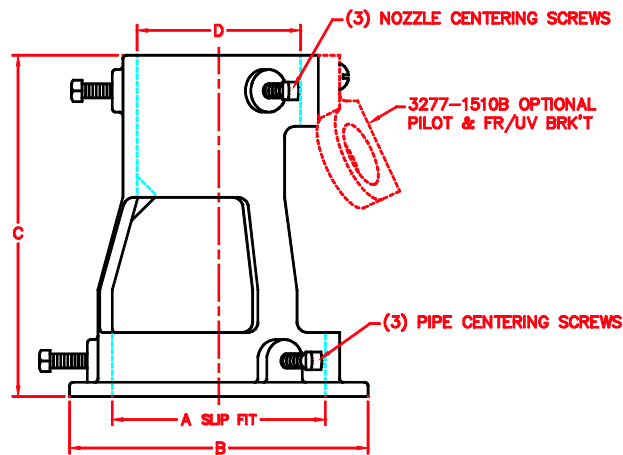

CATALOG NUMBER	A SLIP FIT	B	C	D
20CC	3-1/8	4-5/8	5	2-11/16
24CC	3-3/4	5-1/4	6	2-7/8
32CC	4-3/4	6-1/4	6-3/8	3-1/2
481CC	6-7/8	8-1/2	6-15/16	3-5/8
482CC	6-7/8	8-1/2	6-15/16	4-7/8
64XCC	9	9-1/2	7-13/16	6-1/16

CAUTION: Operation of combustion equipment can be hazardous resulting in bodily injury or equipment damage. Each burner should be supervised by a combustion safeguard and only qualified personnel should install, make system adjustments and perform any required service.



**ORDAN THERMAL PRODUCTS LTD**  
 Combustion Equipment & Controls for Industry  
 21 Amber St # 9, Markham Ontario Canada L3R 4Z3  
 Tel: (905) 475-9292 Fax: (905) 475-3286  
 www.ordanthermal.com

NOTICE: Pyronics practices a policy of continuous improvement in the design of its products. It reserves the right to change the specifications at any time without prior notice.