

# HMCT LOW NO<sub>x</sub> HIGH VELOCITY BURNERS

MODEL: 3720

Revision: 0

BULLETIN  
3720

## DESCRIPTION

Pyronics High-Momentum Ceramic Tube Burners (HMCT) are designed for process temperatures up to 2500°F. The burner's outer tube is made of an advanced silicon carbide and the inner firing tube is made of stainless steel alloy. HMCT Burners are available in two nominal capacity sizes: 650,000 BTU/hr and 1,500,000 BTU/hr.

The burner incorporates 2-stage combustion for low NO<sub>x</sub>. Specifically designed nozzles provide cool NO<sub>x</sub>-inhibiting first stage combustion. Final combustion occurs in the second stage area where combustion products exit at velocities of over 400 fps.

This high velocity drives heat into dense loads and agitates the furnace atmosphere for thorough heat distribution assuring faster through-put.

HMCT Burners function well with either cold or preheated combustion air to temperatures of 700°F.

Light weight SiC firing tubes are self-supporting, eliminating the need for costly and difficult-to-maintain in-furnace support systems. The burners are ideal for installation in either brick or fiber wall furnaces. The burners are easily mounted to the furnace with only four bolts.

The HMCT Burner will work with either Ultraviolet or Flame Rod flame detectors. The need to air purge ultraviolet detectors is greatly reduced because the detector is not directly connected to the combustion chamber where condensation can fog the detector's lens.

Direct spark ignition eliminates the need for high maintenance pilots and allows flexibility in designing the control system. Full Modulation, Gas Only Modulation, High-Low, On-Off and Pulse-Firing are all possible with the HMCT.

An inlet air orifice can be sized to compensate for preheated combustion air. The HMCT will operate at its nominal rating at 20" W. C. whether the combustion air temperature is 60°F or 700°F by adjusting the size of the inlet air orifice.

The HMCT will operate extremely well on most gaseous fuels including Natural Gas, LP Gases, and Clean Manufactured Gases.



## BENEFITS

- High Excess Air Capability
- Low NO<sub>x</sub> Formation
- High Velocity Flame
- Preheated Air Temperature to 700°F
- Self-Supporting SiC Burner Tubes
- Direct Spark Ignition
- Flame Rod or Ultra Violet Flame Detection
- Specifically Engineered Air Inlet Orifice

## APPLICATIONS

- Cover Annealing Furnaces
- Sintering Furnaces
- Slot and Box Type Forge Furnaces
- Nonferrous Melting Furnaces
- Kilns

CAUTION: Operation of combustion equipment can be hazardous resulting in bodily injury or equipment damage. Each burner should be supervised by a combustion safeguard and only qualified personnel should install, make system adjustments and perform any required service.



**ORDAN THERMAL PRODUCTS LTD**  
Combustion Equipment & Controls for Industry  
21 Amber St # 9, Markham Ontario Canada L3R 4Z3  
Tel: (905) 475-9292 Fax: (905) 475-3286  
[www.ordanthermal.com](http://www.ordanthermal.com)

NOTICE: Pyronics practices a policy of continuous improvement in the design of its products. It reserves the right to change the specifications at any time without prior notice.

# HMCT LOW NO<sub>x</sub> HIGH VELOCITY BURNERS

BULLETIN 3720  
PAGE NO. 2

## OPERATING PARAMETERS FOR HMCT BURNERS AT VARIOUS AIR PRESSURES

	Inlet Air Pressure (osi)								
	0.1	0.5	1	2	4	8	10	12	16
<b>Air Flow (scfh)</b>									
650 HMCT	632	1414	2000	2828	4000	5657	6325	6928	8000
1500 HMCT	1581	3536	5000	7071	10,000	14,142	15,811	17,321	20,000
<b>Inlet Gas Pressure (osig)</b>									
650 HMCT	0.05	0.24	0.45	0.94	1.88	3.75	4.7	5.64	7.5
1500 HMCT	0.07	0.35	0.7	1.38	2.75	5.5	6.88	8.24	11
<b>Maximum XSAir (percent)</b>									
650 HMCT	1000	1500	3000	3000	3000	3000	3000	3000	3000
1500 HMCT	1000	1500	3000	3000	3000	3000	3000	3000	3000
<b>Ignition Limits:</b>									
650 HMCT	Ignites at all stoichiometric and XSAir firing rates with 6000v full wave transformer.*								
1500 HMCT	Ignites at all stoichiometric and XSAir firing rates with 6000v full wave transformer.*								

\* Half-wave transformers require XSAir at a pressure above 2 osi.

## 650 HMCT GENERAL DIMENSIONS

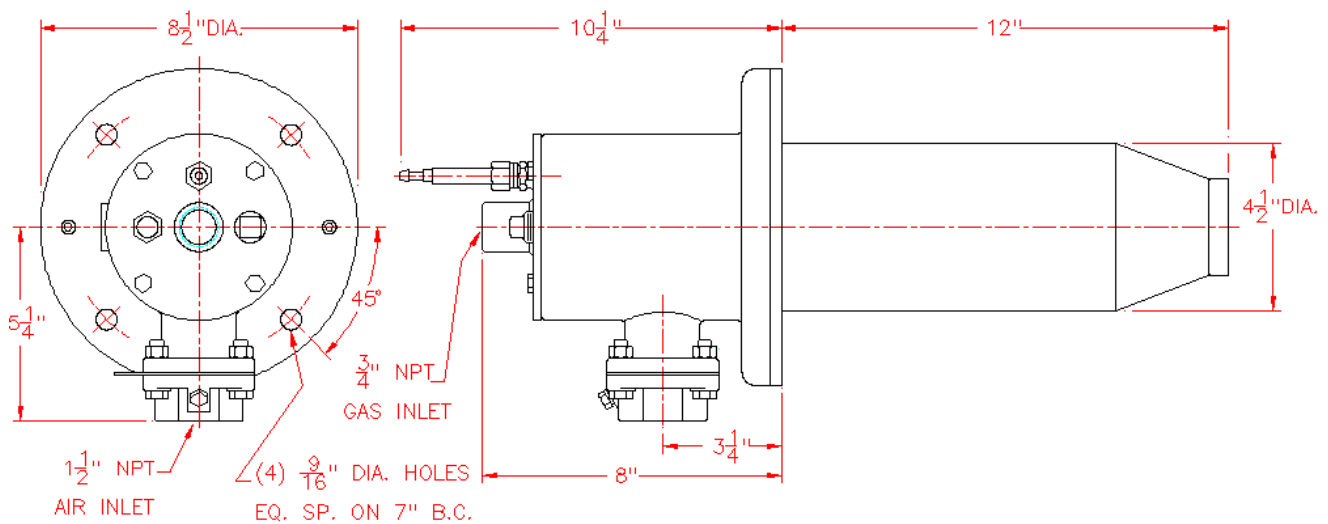

**CAUTION:** Operation of combustion equipment can be hazardous resulting in bodily injury or equipment damage. Each burner should be supervised by a combustion safeguard and only qualified personnel should install, make system adjustments and perform any required service.

# HMCT LOW NOx HIGH VELOCITY BURNERS

BULLETIN 3720  
PAGE NO. 3

## 1500 HMCT GENERAL DIMENSIONS

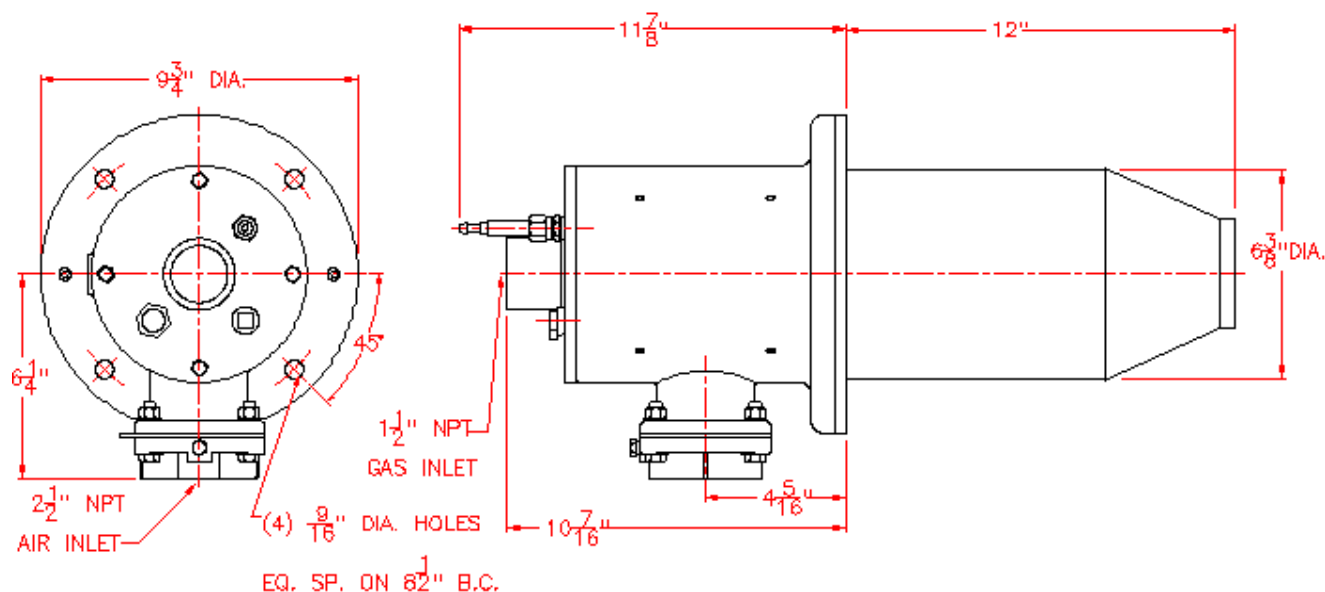

## ORDERING INFORMATION

1. Specify the HMCT Burner Model Number.
2. Specify the quantity of HMCT Burners required.
3. Specify UV Scanner or Flame Rod. UV scanners and flame rods are not included with the basic burner assembly.
4. If preheated combustion air will be used the preheat temperature must be noted at the time of ordering.
5. Special inlet orifices can be supplied for accomodating various air pressures and/or control systems.

CAUTION: Operation of combustion equipment can be hazardous resulting in bodily injury or equipment damage. Each burner should be supervised by a combustion safeguard and only qualified personnel should install, make system adjustments and perform any required service.



**ORDAN THERMAL PRODUCTS LTD**  
Combustion Equipment & Controls for Industry  
21 Amber St # 9, Markham Ontario Canada L3R 4Z3  
Tel: (905) 475-9292 Fax: (905) 475-3286  
[www.ordanthermal.com](http://www.ordanthermal.com)

NOTICE: Pyronics practices a policy of continuous improvement in the design of its products. It reserves the right to change the specifications at any time without prior notice.