

# MP2 Series

## Programmable Temperature Control System



The MP2 system is the next generation of Maxitrol's MP Series programmable process and temperature control systems. It has been designed utilizing the latest technology. The controller is capable of meeting complex processing needs while maintaining an easily understood operator interface.

Exceptional temperature control is maintained with the MP2 system. The system directly controls Maxitrol's industry leading Selectra modulating gas valves. It is ideal for process applications requiring 60°F to 240°F temperature parameters. Virtually any modulating heater can be turned into a process heater simply by adding the MP2 system.

**It has been design engineered for paint spray booths and low temperature process applications.**

The system is designed to handle temperature critical and time sensitive processes. Each heating program can utilize up to 8 temperature Set Points each with timing capabilities. You can offer your customer more timed processes (i.e. purge, multiple bakes, cool down, ...) without adding cumbersome wiring, labor and costly timer components. This also gives the designer as well as the user complete freedom and flexibility with the system.

The intuitive programming menu simplifies set up, operations and diagnostics significantly giving less chance of error. The high definition LCD display with white background and black lettering quickly and easily identifies the current process and related values.

Multiple features allow you to fine tune the MP2 system for your particular needs thereby increasing the performance of any process heater. One example, temperatures can be raised and lowered slowly over a preset time from Set Point to Set Point.

For an explanation of all of the MP2 features please contact your Maxitrol sales representative, visit our website at [www.maxitrol.com](http://www.maxitrol.com) or call 248.356.1400.

### Some Features

- Compact modular design.
- Durable water resistant cover.
- EEPPROM memory eliminates battery backup.
- Selectable menu lockouts to limit end user access.
- 2 resetable Timers for each Set Point including a setable visual alarm.
- Process Indication Output for each Set Point.
- Diagnostic Monitor mode.
- Many other notable features not mentioned.



Batch Oven



Components

**TDM02**

Remote Selector Display Interface



**AM02**

Amplifier



**TM02** (optional)

Auxiliary Multi-function Timer Control



MP2.MS.EN.07.01.05

© Copyright 2005, Maxitrol Company. All Rights Reserved.

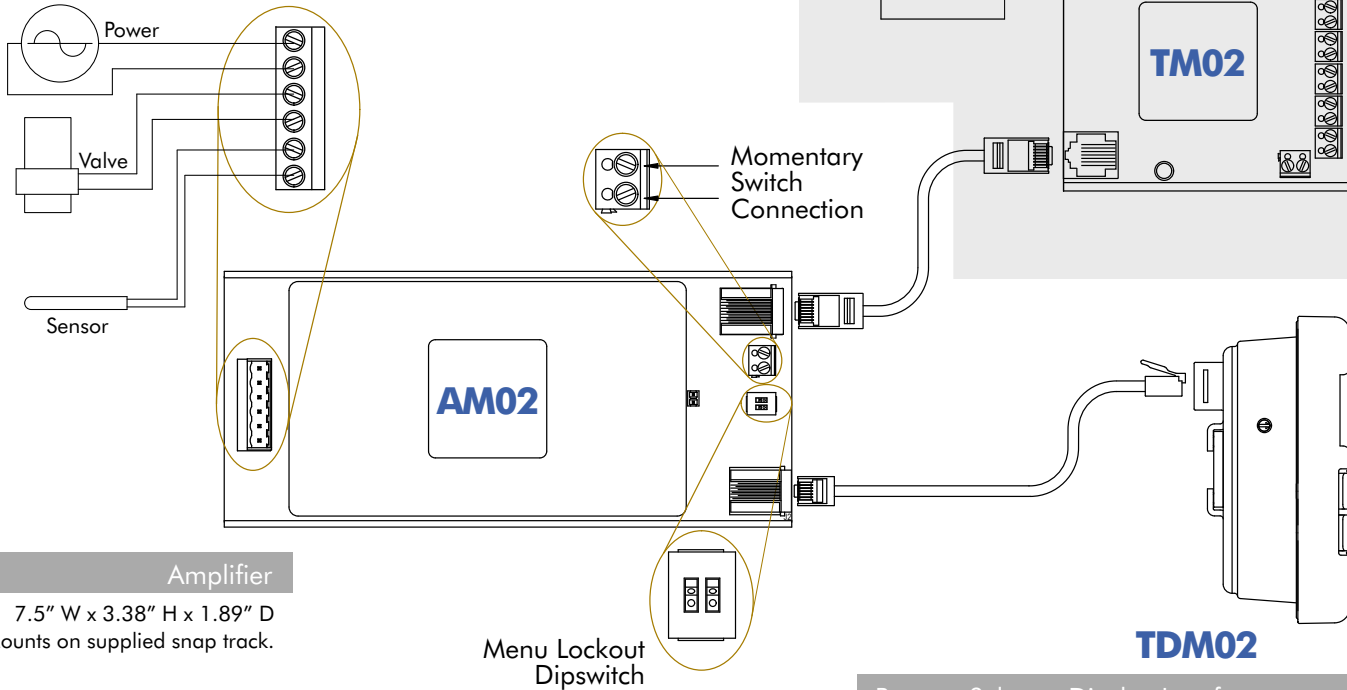

Auxiliary Multi-function Timer Control

(Optional) 5.25" W x 3.75" H x 1.75" D  
Mounts on supplied snap track.

Amplifier

7.5" W x 3.38" H x 1.89" D  
Mounts on supplied snap track.

Menu Lockout  
Dipswitch

**TDM02**

Remote Selector Display Interface  
Standard 1/4 DIN panel mount.