



Selectra[®] SERIES 44 INSTALLATION INSTRUCTIONS and field service checklist

System Components

Amplifiers:

- A1044 (min. 40° to 80° F/ max. 80° to 140° F)
- A1044C (min. 20° to 60° F/ max. 80° to 140° F)
- A1044D (min. 20° to 60° F/ max. 35° to 75° F)
- A1044E (min. 20° to 60° F/ max. 60° to 120° F)
- A1044L1, A1044CL1, A1044DL1, A1044EL1, A1044FL1 - above ranges with adjustable low fire start duration

NOTE: Amplifier and Discharge Temperature Sensor must have same temperature range to be compatible.

Discharge Temperature Sensors: use with Mixing Tube

- TS144 (min. 40° to 80° F/max. 80° to 140° F)
- TS144C (min. 20° to 60° F/max. 80° to 140° F)
- TS144D (min. 20° to 60° F/max. 35° to 75° F)
- TS144E (min. 20° to 60° F/max. 60° to 120° F)
- TS144F (min. 40° to 60° F/max. 60° to 95° F)

Mixing Tubes: used with Sensors

- MT1-9 or MT2-9 (9" length)
- MT1-12 or MT2-12 (12" length)
- MT1-23 or MT2-23 (23" length)
- MT1-28 or MT2-28 (28" length)
- MT1-57 (57" length)

Valves:

- M411 (3/8" & 1/2" pipe size)
- M511 (1/2" & 3/4" pipe size)
- M611 (3/4" & 1" pipe size)
- MR212D (1", 1 1/4", 1 1/2" pipe size)
- MR212E (1 1/2" & 2" pipe size)
- MR212G (2 1/2" & 3" pipe size)
- MR212J (4" flanged)
- MR212D-2, E-2, G-2 & J-2 (same pipe sizes as MR212D-J except used for 2-speed blower or dual fuel operation)

NOTE: M (Modulator) valve requires an upstream pressure regulator for low fire & high fire settings.

MR (Modulator/Regulator) valve requires no upstream pressure regulator up to 5 psi inlet.

Selectrastat (Senses & Selects):

- T244 (55° to 90° F)
- T244A (40° to 80° F)

or optional pair to replace Selectrastat:

Space Temperature Selector:

- TD244 (wall mount 55° to 90° F)
- TD244A (wall mount 40° to 80° F)
- TD244P (panel mount 55° to 90° F)
- TD244AP (panel mount 40° to 80° F)

Space Temperature Sensor:

- TS244 (55° to 90° F)
- TS244A (40° to 80° F)

NOTE: Space Temperature Selector and Space Temperature Sensor must have same temperature range to be compatible.

Table of Contents	
Page 2	Introduction and Dimensions
Page 3	Specifications
	Installation of Components
	Typical Gas Trains
Page 4 & 5	Field Service Checklist
Page 6	Wiring Diagrams
	Valve Adjustments
Page 7	Preliminary Circuit Analysis
Page 8	Temperature Calibration
	Low Fire Start Time Adjustment
	Sensitivity Adjustment



A1044L1 Amplifier



A1044 Amplifier



Selectrastat



Temp. Sensor



Temp. Selector



Valve



Mixing Tube and Sensor

Introduction and Dimensions

Selectra SERIES 44 electronic gas flame modulation systems are designed primarily for space heating, as components of direct fired equipment. They may be field installed on existing equipment or specified for new equipment installation. All fuel gases are compatible.

The systems utilize Modulator or Modulator-Regulator valves to control gas pressure. Amplifiers are available with adjustable low-fire start duration.

A discharge air temperature sensor (and mixing tube) is a means of limiting the minimum and maximum discharge air temperature. The amplifier supplies output voltage to the modulating valve. A wall mounted Selectrastat senses space temperature and has an integral selector with either a 55° to 90° F or 40° to 80° F range. Optionally, a remote Temperature Sensor paired with a separate Temperature Selector can be substituted for the Selectrastat.

SELECTRASTAT, TEMP. SELECTOR, SPACE TEMP. SENSOR

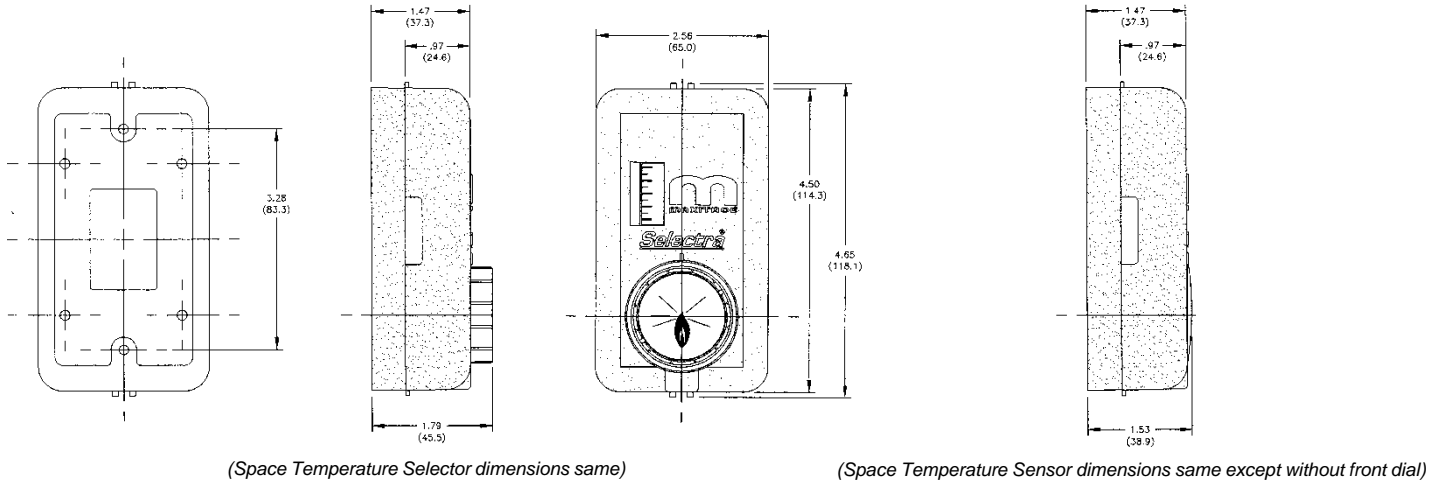

A1044 AMPLIFIER

A1044L1 AMPLIFIER

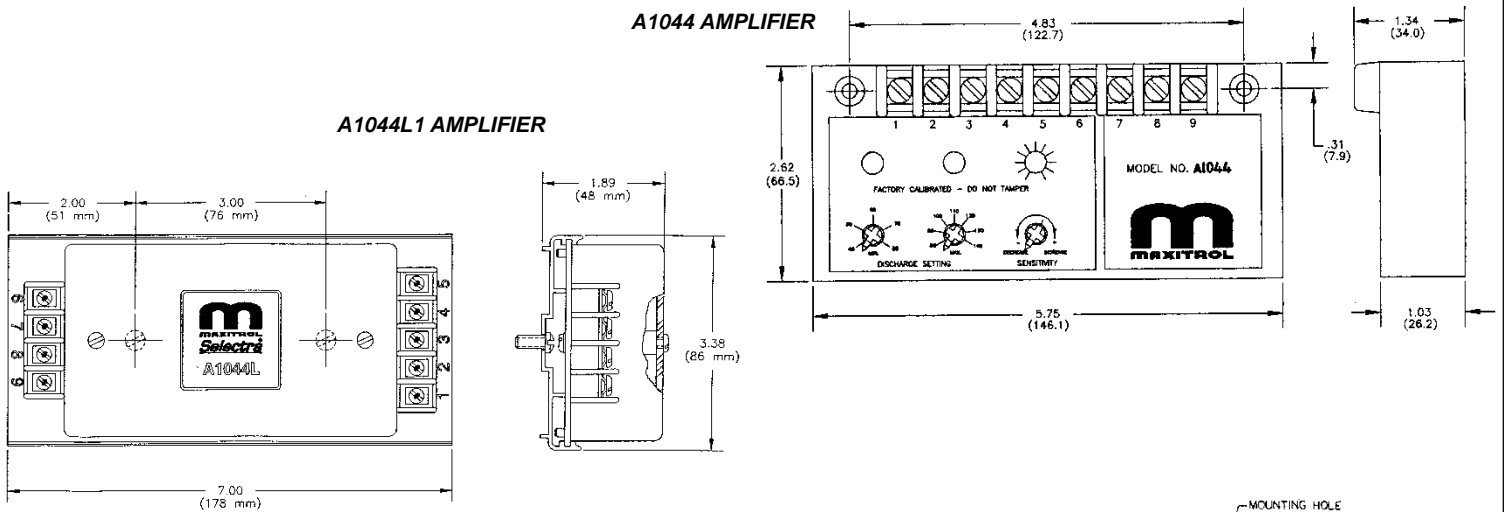

MIXING TUBE (TS144 attaches internally)

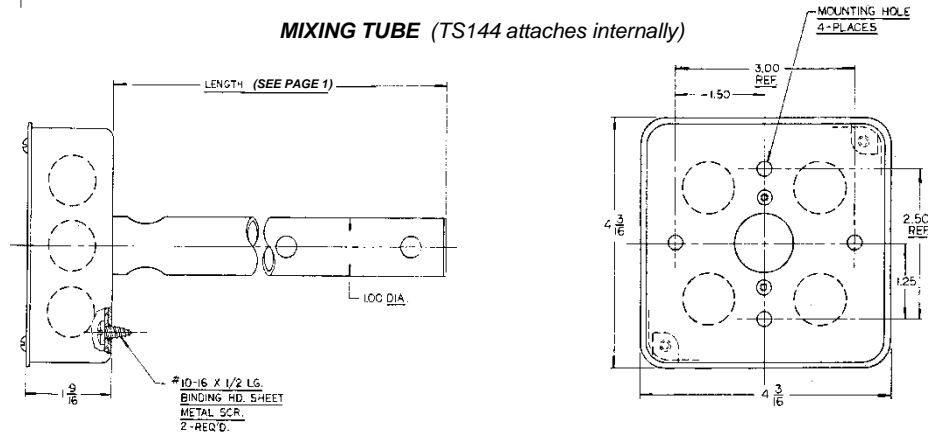

Specifications

Pressure Adjustment Ranges: (Maximum Fire)

Standard (MR212) 2" to 5" w.c. / 5 to 12 mbar

Standard (MR212-2) 2" to 5" w.c. / 5 to 12 mbar
reduced 0" to 3" w.c. / 0 to 7.5 mbar

Vent: Model M411, M511, M611-vertical vent outlet 1/8" NPT—12A06 installed.

MR212—two vents located in upper housing, both equipped with vent limiting means.

Ambient Limits:

Operating -40° to 125° F / -40° to 52° C

Non-Operating -50° to 185° F / -46° to 85° C

Power Requirements: 24 Volts, NEC Class II transformer 20 VA

NOTE: Transformer secondary must not be grounded in any portion of the circuit external to a Maxitrol amplifier. If existing transformer is grounded, a separate isolated transformer must be used. Electrical

interference may effect performance and/or damage equipment.

Gases: All fuel gases

Pressure Limits:

Maximum M411, M511, M611 Outlet Pressure: 7.0" w.c. / 17 mbar

MR212 Outlet Pressure Springs: 1" to 3.5" w.c. / 2.5 to 9 mbar, 2" to 5" w.c. / 5 to 12 mbar, and 3" to 8" w.c. / 7 to 20 mbar

Static Pressure Rating (M411, M511, M611) 5.0 psi / 345 mbar

Maximum Operating Inlet Pressure (MR212) 5.0 psi / 345 mbar

Maximum Emergency Exposure *(MR212)..... 12.5 psi / 862 mbar

*May not function properly at this pressure, but will suffer no internal damage.

Installation of Components

Wiring Run: Control wires connected to the Selectrastat, Discharge Air Sensor, Remote Temperature Selector/Sensor, Amplifier or Valve must not be run close to or inside conduit with power or ignition wires. **Doing so may cause the unit to function erratically or may destroy the amplifier.** If shielded wires are used, shield must be insulated and grounded at the amplifier location only.

Amplifier: Install in any convenient location that is protected from the weather and contaminated atmosphere.

Selectrastat: This component selects and senses space temperature. Remove cover to mount in heated area where representative space temperature can be sensed.

Optional:

Remote Temperature Selector: Not temperature sensitive (selects space temperature). Remove cover to mount in any convenient location. **Note:** *Temperature selector and sensor must have same temperature range to be compatible.*

Remote Temperature Sensor: Senses space temperature. Remove cover to mount in area where representative space temperature is to be sensed.

Typical Gas Trains

Modulator (M) or Modulator-Regulator (MR) Valve: Mount in upright position in horizontal run of pipe, downstream of other controls - a separate gas pressure regulator must be used with any modulator (M) valve.

MR Valve: Modulator-regulator valve

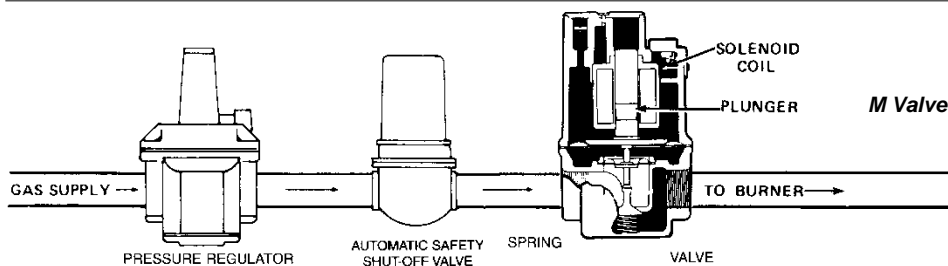
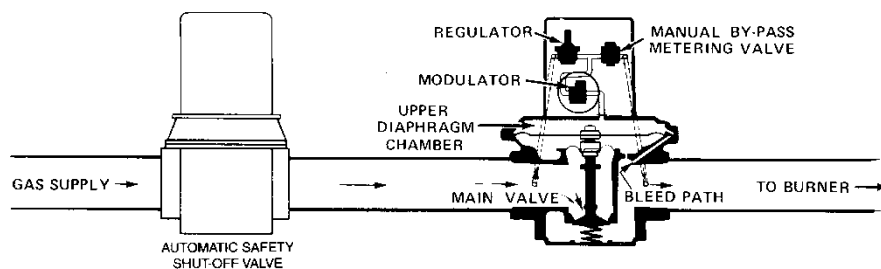

M Valve: Regulator upstream of modulator valve

Field Service Checklist

SYMPTOM		POSSIBLE CAUSE		FIELD TEST		REMEDY	
A.	No gas flow.	1. Valve improperly installed.	1. Arrow on side of valve should point in direction of gas flow.	1. Install properly.	1. Install properly.		
B.	Continuous low fire (electronics OK).	2. Open circuit in modulator coil. 3. Plunger missing, jammed or improperly installed. 4. Ruptured main or balancing diaphragm.	2. Remove wires connected to amplifier terminals 6 & 7 and measure resistance. MR212 (60-80 ohms), M611 (45-55 ohms). 3. Inspect - plunger should be installed (as in figures on page 3) and operate freely in solenoid sleeve. 4. Disassemble valve for inspection of internal parts.	2. If proper resistance values are not observed, replace modulator head or repair wiring. 3. Clean or replace plunger if necessary and install (as in figures on page 3). 4. Replace diaphragm if ruptured.	2. If proper resistance values are not observed, replace modulator head or repair wiring. 3. Clean or replace plunger if necessary and install (as in figures on page 3). 4. Replace diaphragm if ruptured.		
C.	Continuous Low Fire (electronics problem).	5. No voltage to the amplifier. 6. Short in modulator coil circuit. 7. Short in TS144 circuit. 8. Faulty amplifier	5. Check for 24V AC at amplifier terminals 8 & 9. 6. Measure resistance per item 2 7. Remove wires connected to amplifier terminals 1, 2, & 3. Measure resistance across wires 1 & 3, then 2 & 3. Meter should read greater than 2500 ohms. 8. Follow procedures outlined in "PRELIMINARY CIRCUIT ANALYSIS" (Sections I & II).	5. Provide 24V AC to amplifier. Refer to item 24. 6. If proper resistance values are not observed, replace modulator head or repair wiring. 7. If readings are incorrect, replace the TS144 or repair wiring. 8. If power source and modulator coil check of items 5 & 6) but proper modulating voltages cannot be obtained, then amplifier may be assumed at fault. Install replacement amplifier.	5. Provide 24V AC to amplifier. Refer to item 24. 6. If proper resistance values are not observed, replace modulator head or repair wiring. 7. If readings are incorrect, replace the TS144 or repair wiring. 8. If power source and modulator coil check of items 5 & 6) but proper modulating voltages cannot be obtained, then amplifier may be assumed at fault. Install replacement amplifier.		
D.	Incorrect Low Fire.	9. Incorrect by-pass metering valve adjustment. 10. Excessive negative burner pressure.	9. See Valve Adjustments - Page 6. 10. Close main gas supply and measure manifold pressure with blower operating. Should be less than 1.5" w.c. negative pressure	9. Adjust to proper low fire. 10. If greater than 1.5" negative pressure, check equipment for clogged filters & other inlet air restrictions. For other solutions, consult Maxitrol.	9. Adjust to proper low fire. 10. If greater than 1.5" negative pressure, check equipment for clogged filters & other inlet air restrictions. For other solutions, consult Maxitrol.		
E.	Continuous Minimum Discharge Air Temperature.	11. Faulty amplifier. 12. Short in T244 or TS244/TD244 circuit. 13. Incorrect space temperature calibration.	11. Follow procedures outlined in "PRELIMINARY CIRCUIT ANALYSIS" (Sections I & II). 12. Remove wires connected to amplifier terminals 4 & 5. Set T244 or TD244 to maximum setting. Measure resistance across wires. Meter should read 6000 ohms + 1000 (T244). If TS244/TD244 are used, meter should read 4500 ohms + 1000 (TS244) and 2100 ohms + 150 (TD244). 13. Follow procedures outlined in "PRELIMINARY CIRCUIT ANALYSIS" (Sections IV).	11. If amplifier is proven at fault, install replacement amplifier. 12. If reading is incorrect, replace the T244, TS244/TD244 or repair wiring. 13. If proper action is obtained, first check item 12. Recalibrate if necessary - Pg. 8.	11. If amplifier is proven at fault, install replacement amplifier. 12. If reading is incorrect, replace the T244, TS244/TD244 or repair wiring. 13. If proper action is obtained, first check item 12. Recalibrate if necessary - Pg. 8.		
F.	Incorrect Max. or Min. Discharge Air Temperature.	14. Improper TS144 location. 15. Incorrect discharge air temperature calibrations.	14. Compare sensed temperature reading at TS144 with average discharge air temperature. Follow procedures outlined in "PRELIMINARY CIRCUIT ANALYSIS" (Sections IV).	14. Move TS144 to location where average temperature can be sensed. If proper temperatures are not observed, refer to Discharge Air Temperature calibration procedures - Page 8.	14. Move TS144 to location where average temperature can be sensed. If proper temperatures are not observed, refer to Discharge Air Temperature calibration procedures - Page 8.		
G.	Continuous High Fire. (electronics OK)	16. Foreign material holding valve open. 17. Plunger jammed.	16. Remove bottom Plate and inspect valve and seat 17. Inspect - plunger should be smooth and clean and operate freely in solenoid sleeve.	16. Clean, replace valve and/or seat if necessary. 17. Clean, or if necessary, replace plunger.	16. Clean, replace valve and/or seat if necessary. 17. Clean, or if necessary, replace plunger.		
H.	Continuous High Fire. (electronics problem)	18. Open circuit in TS144.	18. Measure resistance per item 7.	18. If readings are incorrect, replace the TS144 or repair wiring.	18. If readings are incorrect, replace the TS144 or repair wiring.		
I.	Incorrect High Fire.	19. Inlet pressure too low. 20. Incorrect outlet pressure adjustment.	19. Read inlet pressure at valve, using a manomete with heater operating at full fire. Pressure should be at least equal to the sum of: outlet pressure setting and pressure drop of the valve (See Maxitrol Capacity Chart Bulletin) plus 1.0" w.c. 20. Read outlet pressure using manomete and compare with recommendation of equipment manufacturer.	19. Increase inlet pressure if possible or change to larger valve. Consult Maxitrol about possibility of using special spring to reduce pressure drop on selected installations. 20. See valve adjustments - page 6.	19. Increase inlet pressure if possible or change to larger valve. Consult Maxitrol about possibility of using special spring to reduce pressure drop on selected installations. 20. See valve adjustments - page 6.		
J.	Continuous Maximum Discharge Air Temperature.	21. Faulty amplifier. 22. Open circuit in T244 or TS244/TD244. 23. Incorrect space temperature calibration.	21. Follow procedure outlined in "PRELIMINARY CIRCUIT ANALYSIS" (Sections I & II). 22. Measure resistance per item 12. 23. Follow procedures outlined in "PRELIMINARY CIRCUIT ANALYSIS" (Section IV).	21. If amplifier is proven at fault, install replacement amplifier. 22. If reading is incorrect, replace the T244, TS244/TD244 or repair wiring. 23. If proper action is obtained, first check item 22. Recalibrate if necessary - page 8.	21. If amplifier is proven at fault, install replacement amplifier. 22. If reading is incorrect, replace the T244, TS244/TD244 or repair wiring. 23. If proper action is obtained, first check item 22. Recalibrate if necessary - page 8.		
K.	Burned out Transformer. No Voltage to Amplifier.	24. Short in modulator coil circuit.	24. Measure resistance per item 2.	24. If proper resistances are not observed, replace modulator head or repair wiring.	24. If proper resistances are not observed, replace modulator head or repair wiring.		
L.	Incorrect Space Temperature.	25. Incorrect maximum discharge air temperature setting A1044). 26. Incorrect minimum discharge air temperature setting (A1 044). 27. Insufficient burner capacity. 28. Incorrect space temperature calibration.	25. Check to see if heater is delivering air at maximum discharge air setting. 26. Check to see if heater is delivering air at minimum discharge air setting. 27. Check to see if heater is operating at high fire. 28. Place thermometer next to T244 or TS244. Compare space temperature reading with T244 or TD244 dial setting.	25. If desired temperature is not reached, increase maximum discharge air temperature setting. 26. If desired space temperature is not reached, decrease minimum discharge air temperature setting. 27. If desired space temperature is not reached with heater at high fire, it may be oversized. Consult equipment manufacturer. If temperature reading is incorrect, check items 25, 26 & 27, then recalibrate if necessary.	25. If desired temperature is not reached, increase maximum discharge air temperature setting. 26. If desired space temperature is not reached, decrease minimum discharge air temperature setting. 27. If desired space temperature is not reached with heater at high fire, it may be oversized. Consult equipment manufacturer. If temperature reading is incorrect, check items 25, 26 & 27, then recalibrate if necessary.		
<p>*Control circuits external to the Series 44 can cause burner malfunction. Always check manual valve to be certain gas is on, and check limit controls for normal operation.</p>							

Wiring Diagrams

Amplifier with Selectrastat

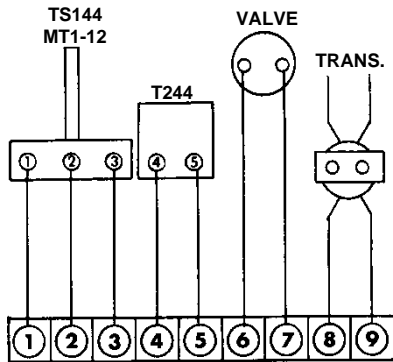

Amplifier with remote temperature sensor and separate temperature selector

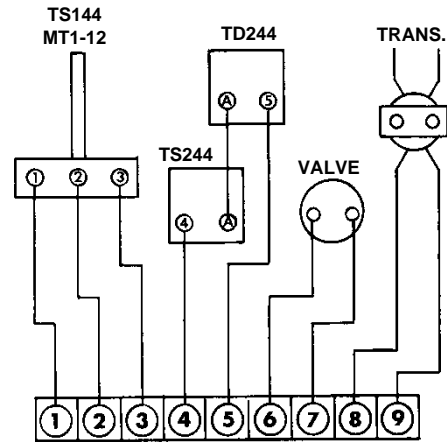

(Terminal locations shown for A1044 [and C, D, E] model amplifiers.

A1044L1 [and CL1, DL1, EL1] model terminal blocks 1-5 and 6-9 are at opposite ends of the board)

Valve Adjustments

(See bulletin MT2035 for additional M/MR valve information)

NOTE: Low fire adjustment should be checked whenever the high fire adjustment is changed.

MR 212 VALVE

High Fire Manifold Adjustments:

1. Disconnect wires from amplifier terminal #2 & #4.
This causes the valve to go to continuous high fire.
2. Remove seal cap (A), and turn regulator pressure adjusting screw to obtain desired manifold pressure. (Clockwise rotation increases pressure.)
3. Reconnect the wires to amplifier terminal #2 & #4.

NOTE: If low fire bypass is on maximum, the desired high fire outlet pressure may not be achieved.

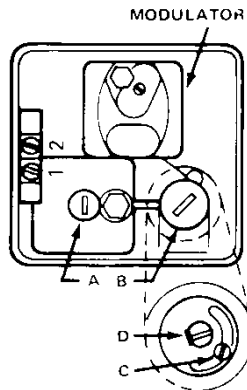

Low Fire or Bypass Adjustments:

1. Disconnect wire from amplifier terminal #8, this causes valve to go to continuous low fire.
2. Remove cap (B), and loosen lock screw (C). Turn (D) to desired low fire adjustment. (Clockwise rotation reduces minimum flow rate.)
3. Tighten set screw (C), replace cap (B) and reconnect wire to amplifier terminal #8.

M411, 511, 611 VALVE

High Fire Manifold Adjustments:

1. Disconnect wires from amplifier terminal #2 & #4, this causes the valve to go to continuous high fire.
2. Adjust the upstream pressure regulator to obtain the desired manifold pressure (7" w.c. maximum).
3. Reconnect the wires to amplifier terminal #2 & #4.

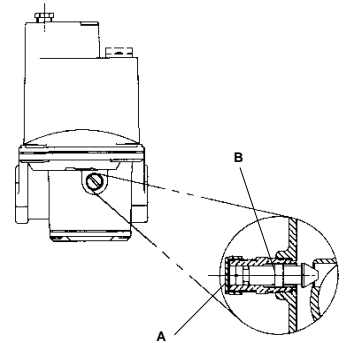

Low Fire or Bypass Adjustments:

1. Disconnect wire from amplifier terminal #8, this causes the valve to go to continuous low fire.
2. Remove cap (A), and turn adjusting screw (B) to desired low fire adjustment. (Clockwise rotation reduces minimum flow rate.)
3. Replace cap (A), and reconnect wire to amplifier terminal #8.

CAUTION: Operation of combustion equipment can be hazardous resulting in bodily injury or equipment damage. Each burner should be supervised by a combustion safeguard and only qualified personnel should install, make system adjustments and perform any required service.



ORDAN THERMAL PRODUCTS LTD
Combustion Equipment & Controls for Industry
 21 Amber St # 9, Markham Ontario Canada L3R 4Z3
 Tel: (905) 475-9292 Fax: (905) 475-3286
www.ordanthermal.com

NOTICE: Maxitrol practices a policy of continuous improvement in the design of its products. It reserves the right to change the specifications at any time without prior notice.

Preliminary Circuit Analysis

This Preliminary Circuit Analysis will provide identification of faulty components, improper wiring or calibration, and other difficulties when used with the tabulated Field Service Checklist (pages 4 & 5).

Note: All voltages and resistance readings are approximate.

Section I

1. Wire the system (per Figure 1 below).
2. Connect a DC voltmeter to amplifier terminals #6 & #7.
3. Turn the Test-Potentiometer to minimum resistance. (2,000 ohms). The DC voltage should read 0 volts.
4. Turn the Test-Potentiometer slowly to maximum resistance (12,000 ohms). The DC voltage should gradually increase to at least 18 volts.

If proper voltages are observed continue on with Section II.

If proper voltages are not observed, the problem is identified with the Amplifier, the 24-volt AC power supply, or the circuit connected to terminals #6 & #7.

Section II

1. Turn power OFF, wire system (per Figure 2 below), turn power ON.
2. Turn Test-Potentiometer to minimum resistance, the voltage should be 0 volts.
3. Turn Test-Potentiometer slowly to maximum resistance, the DC voltage should gradually increase to at least 18 volts.

If proper voltages are observed in both Sections I & II, the amplifier is satisfactory.

If proper voltages are not observed, continue testing to identify the difficulty. Faults may be identified with the amplifier, the 24V power supply, or the circuit connected to terminals #6 & #7. See Field Service Checklist.

Section III

1. Observe burner flames and/or burner pressure as Test-Potentiometer is turned through full range. **Note:** From 0-5 volts, heater should be at by-pass or low, 5-15 volts, heater should respond with various input rates; beyond 15 volts, heater is at maximum input.

If proper operation is observed, continue procedure to check operation of sensing and selecting components.

If proper operation is not observed, see Field Service Checklist to test M or MR valves and connecting wiring.

Section IV

1. With proper voltages observed thus far and modulator responding correctly, wire the system (see Figure 1 below), except have TS144 connected in place of jumper. Set MIN temperature selector at least 10° F above outdoor temperature. Set MAX

temperature selector at mid-range. Heater is now under control by the



(or)

TS144 Discharge Air Monitor.

2. Turn Test-Potentiometer to maximum resistance, delivered air temperature should be per MAX temperature setting. Turn Test-Potentiometer to minimum resistance, delivered air temperature should be per MIN temperature setting. If proper delivered air temperatures are observed, the problem is identified with the space temperature sensing and/or temperature selecting components and circuits. See Field Service Checklist.



If proper delivered air temperatures are not observed, check calibration. See Field Service Checklist.

Section V

1. After test, remove all test equipment and reconnect all components.

Figure 1

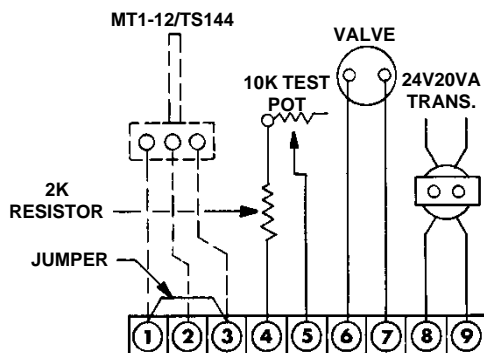
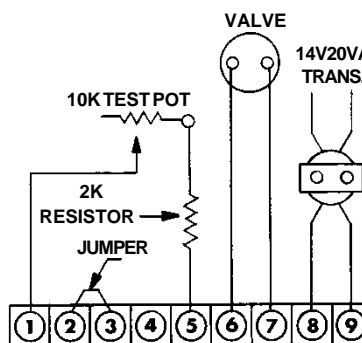

Figure 2



(Terminal locations shown for A1044 [and C, D, E] model amplifiers.

A1044L1 [and CL1, DL1, EL1] model terminal blocks 1-5 and 6-9 are at opposite ends of the board)

Temperature Calibration

Note: All electronic components are pre-calibrated to a base resistance. This permits field replacement without upsetting system calibration.

Minimum Discharge Air Temperature

1. Install a thermometer or other temperature measuring device at a point adjacent to the tip of the TS144.
2. Connect a wire jumper between terminals #4 and #5. Be sure minimum temperature setting is at least ten degrees higher than outdoor temperature.
3. Turn the calibrating potentiometer (A) until the reading of the thermometer adjacent to the TS144 agrees with the minimum setting of the Discharge Air Temperature Selector. Clockwise rotation increases temperature (A1044L model adjusted from blue side).
4. Remove jumper.

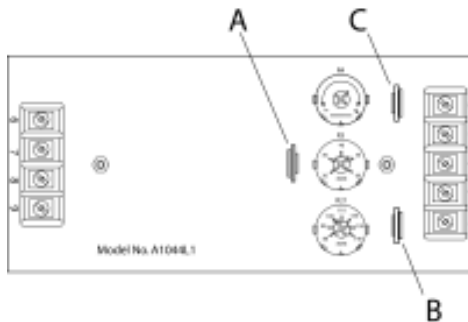
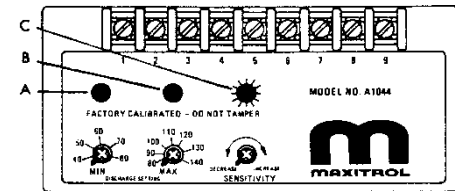

3. Turn the calibrating potentiometer (B), until the reading of the thermometer adjacent to the TS144 agrees with the maximum setting of the Discharge Air Temperature Selector. Clockwise rotation increases temperature (A1044L1 model adjusted from blue side). Be sure temperature setting does not exceed the design temperature rise of the heater.

4. Remove resistor and reconnect wires.

Space Temperature

1. Install a thermometer or other temperature measuring device at a point adjacent to the T244 or the TS244. Set the T244 or the TD244 (whichever is used) for the desired room temperature. Because of the large space being heated, wait at least one half hour* to make certain adjustment is needed.
2. If the temperature reading is different from the temperature setting, turn (C) clockwise for an increase in

space temperature and counterclockwise for a decrease in temperature. Each increment on adjustment C is approximately 2.5 degrees (A1044L1 model adjusted from blue side). After an adjustment has been made, give the room temperature at least one half hour* to settle out before rechecking.

* One half hour is only a time estimate. Longer or shorter periods may be required for the temperature to stabilize. Be sure space temperature is stabilized before attempting calibration!

Maximum Discharge Air Temperature

1. Install a thermometer or other temperature measuring device at a point adjacent to the tip of the TS144.
2. Disconnect wires from terminals #4 & #5. Connect 12K resistor across terminals #4 & #5.

Low Fire Start Time Adjustment

On A1044L1 (CL1, DL1, EL1) amplifiers, the low fire start duration is adjustable from approximately 0-30 seconds, and begins timing after the amplifier has been energized.

High fire is delayed, and the M/MR valve remains in the low fire setting position during the delay time period.

Use a small screwdriver to adjust the time delay potentiometer.

Turn clockwise (+) to increase low fire start duration, and counter-clockwise (-) to decrease low fire start duration.

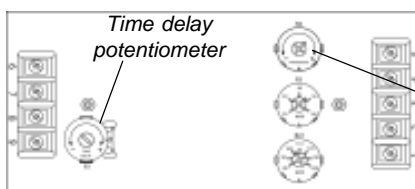

A1044L1 (CL1, DL1, EL1)
cover removed

Sensitivity adjustment



A1044 (C, D, E)
model amplifier

Sensitivity Adjustment

The sensitivity control will allow the user to control the response of the system. Caution should be exercised in the use of this adjustment. Under normal usage the pointer should be located on the mark of the label.

If hunting is encountered (rapid oscillation), rotating the sensitivity control counterclockwise may dampen the oscillation, stabilizing the flame.

DO NOT adjust unless necessary, because decreasing the sensitivity will increase the temperature "DROOP" of the system.

CAUTION: Operation of combustion equipment can be hazardous resulting in bodily injury or equipment damage. Each burner should be supervised by a combustion safeguard and only qualified personnel should install, make system adjustments and perform any required service.



ORDAN THERMAL PRODUCTS LTD
Combustion Equipment & Controls for Industry
21 Amber St # 9, Markham Ontario Canada L3R 4Z3
Tel: (905) 475-9292 Fax: (905) 475-3286
www.ordanthermal.com

NOTICE: Maxitrol practices a policy of continuous improvement in the design of its products. It reserves the right to change the specifications at any time without prior notice.

MAXITROL[®]  **company**

CAUTION: Operation of combustion equipment can be hazardous resulting in bodily injury or equipment damage. Each burner should be supervised by a combustion safeguard and only qualified personnel should install, make system adjustments and perform any required service.



ORDAN THERMAL PRODUCTS LTD
Combustion Equipment & Controls for Industry
21 Amb St # 9, Markham Ontario Canada L3R 4Z3
Tel: (905) 475-9292 Fax: (905) 475-3286
www.ordanthermal.com

NOTICE: Maxitrol practices a policy of continuous improvement in the design of its products. It reserves the right to change the specifications at any time without prior notice.