

FLANGED MIXING TEES

MODEL: 2361 - FMT

Revision: 0

BULLETIN
2361

FEATURES

- Compact economical air-gas mixers.
- High capacity with low pressure drop.
- Mixers designed for single burners or multiple burners connected to a common manifold.
- 1-1/4" to 8" I. P. S. mixture connections.
- Integral gas adjusters.
- Single valve control of heat input.
- Flanged construction -- no pipe union required.
- Rugged cast iron construction.



10-FMT MIXING TEE

DESCRIPTION

Flanged Mixing Tees are air-gas proportional type mixers designed for low pressure drop operation. Combustion air delivered through a control valve is metered through a precision machined orifice. Controlled air pressure is impulsed to the top of the gas balanced zero regulator.

The zero regulator outlet pressure will always be the same as the controlled air pressure. An adjustable gas orifice sets the gas fuel flow rate. This pressure interlocked system maintains equal air and gas pressure drops at all flow rates. Air-gas ratio will be constant over the entire turndown range of the system.

AIR CAPACITY TABLE IN CUBIC FEET PER HOUR

Hi-Fire Air Pressure Drop Across FMT Mixer, Inches W.C.	0.07	0.3	1.1	2.5	4.5	7.0	10.0	13.8
Maximum Mixer Turndown Ratio	None	2 to 1	4 to 1	6 to 1	8 to 1	10 to 1	12 to 1	14 to 1
10FMT-25	250	500	1000	1500	2000	2500	3000	3500
12FMT-35	350	700	1400	2100	2800	3500	4200	4900
16FMT-50	500	1000	2000	3000	4000	5000	6000	7000
16FMT-60	600	1200	2400	3600	4800	6000	7200	8400
20FMT-80	800	1600	3200	4800	6400	8000	9600	11200
24FMT-100	1000	2000	4000	6000	8000	10000	12000	14000
24FMT-120	1200	2400	4800	7200	9600	12000	14400	16800
32FMT-150	1500	3000	6000	9000	12000	15000	18000	21000
32FMT-200	2000	4000	8000	12000	16000	20000	24000	28000
32FMT-250	2500	5000	10000	15000	20000	25000	30000	35000
48FMT-350	3500	7000	14000	21000	28000	35000	42000	49000
48FMT-500	5000	10000	20000	30000	40000	50000	60000	70000
48FMT-600	6000	12000	24000	36000	48000	60000	72000	84000
4864FMT-700	7000	14000	28000	42000	56000	70000	84000	98000
4864FMT-800	8000	16000	32000	48000	64000	80000	96000	112000

NOTES: Gas capacity is 100 BTU/Hr. for each cubic foot of air/Hr..

Gas Pressure to inlet of zero governors must be at least 1.0" higher than available blower air pressure.

Mixer turndown capability should always exceed burner turndown capability.

CAUTION: Operation of combustion equipment can be hazardous resulting in bodily injury or equipment damage. Each burner should be supervised by a combustion safeguard and only qualified personnel should install, make system adjustments and perform any required service.



ORDAN THERMAL PRODUCTS LTD
 Combustion Equipment & Controls for Industry
 21 Amber St # 9, Markham Ontario Canada L3R 4Z3
 Tel: (905) 475-9292 Fax: (905) 475-3286
www.ordanthermal.com

NOTICE: PYRONICS practices a policy of continuous improvement in the design of its products. It reserves the right to change the specifications at any time without prior notice.

MIXER SELECTION

FMT mixer selections are based on blower air pressure available, mixture pressure required at the burners, BTU/hr. input, percentage primary aeration and turndown ratio required.

The burner selection will determine the total input, mixture quality, mixture pressure, and turndown. The turndown ratio determines the air pressure drop required across the mixer.

The sum of the high fire burner mixture pressure, pressure drop

across the mixture, pressure losses in the air supply to the mixer and furnace pressure determines the minimum blower air pressure required.

The capacity table shows the air flow through each mixer in cubic feet per hour at various pressure drops. Air pressure through the mixer develops the mixer pressure. Gas capacities are determined by the primary aeration required by the burners. Mixer designs are adequate to permit gas flow up to 20% of the air flows.

MIXER SELECTION PROCEDURE

1. Burner selections are based on the total heat input required by the process, heat dispersion and heat turndown requirements. Multiply the BTU/hr. by the percentage aeration or primary air of the burners, expressed as a decimal, and divide by 100 to determine CFH air flow required. See Burner Bulletins for percent aeration for normal operation.
2. The low fire point of a burner is determined by its design and is usually stated. The turndown ratio of the burner is based on high fire mixture pressure and the low points. Divide high fire capacity by low fire capacity for turndown ratio.
3. Select the mixer under the turndown ratio column, from #2, for the air capacity required (from #1 above).
4. Determine pressure drop across the mixer and add to high fire burner mixture pressure. Add estimated air pipe pressure losses and furnace back pressure if applicable. Total is the minimum blower air pressure required.
5. Select the blower for the air capacity and minimum air pressure. Pick next higher pressure class if minimum is between two classes. Do not undersize on air capacity.
6. Higher blower air pressures will deliver higher mixture pressure and increased pressure drops across the mixer. These will be in direct proportion to the ratio of the blower pressure selected, divided by the minimum air pressure calculated. Capacity increase of the system will be directly proportional to the square root of this ratio.

SELECTION EXAMPLE

Pyroline Burners are required for an air heater with a maximum heat input of 1,200,000 BTU/hr. and a minimum of 300,000 BTU/hr. Air velocity past the burner will be 1000 FPM.

1. From Pyroline Burner Bulletin 3201 minimum mixture pressure is 1/2" w.c. and best operation is at 75% primary air.
2. Turndown ratio required by the burner is 1,200,000 BTU/hr. divided by 300,000 BTU/hr. or 4 to 1. This requires 8" w.c.

initial mixture pressure on the burners (see Bulletin). Recommend mixer selection for 6 to 1 turndown for better control.

3. Air required thru mixer: $1,200,000 \text{ BTU/hr.} \times 0.75 \text{ aeration} / 100 = 9,000 \text{ CFH.}$
4. From capacity table select 32FMT-150. When capacity falls between two sizes always select smaller size.

SELECTION EXAMPLE - (CONTINUED)

5. High fire pressure drop across mixer of 2.5" w. c. plus burner mixture pressure of 8.0" w. c. and estimated air piping pressure losses of 2.0" w. c. totals 12.5" w. c. minimum blower air pressure.
6. Select an 8 osi class blower for 150 CFM or higher. With blower air pressure higher than minimum required, mixture pressure capacity and pressure drop across mixer will be slightly higher.

7. 8 osi x 1.73 inch/osi = 13. 8" w. c. blower pressure.

$$\frac{13.8"}{12.5"} = 1.1 \text{ pressure ratio}$$

Mixture pressure expected at burner = 8 x 1.1 = 8.8" w. c.

Pressure drop expected across mixer = 2.5 x 1.1 = 2.75" w. c.

Actual capacity expected = 1,200,000 x $\sqrt{1.1}$ = 1,260,000 BTU/hr.

INSTALLATION AND OPERATING INSTRUCTIONS

INSTALLATION INSTRUCTIONS

1. The recommended gas pressure to the BZR Regulator should be at least 4" w. c. higher than maximum controlled air pressure.

The system should be piped according to layout on page 4. Local codes, insurance and other requirements should be followed.

2. The air and gas supply piping and mixture manifold should be the same size or larger than the pipe sizes on the FMT mixer body. Pressure losses in mixture piping should be kept less than 1" w. c. Use larger pipe if necessary.

OPERATING INSTRUCTIONS

1. Check that the air and gas supply, valves and regulators are adequate for the requirements.
2. Check that gas supply is off and the gas adjustor is closed.

3. Set butterfly valve one-quarter open.

4. Light pilot or apply torch to burner. Open main gas cock to full open. Adjust gas flow to desired mixture quality.

5. Slowly increase air pressure to maximum. If gas pressure is adequate the mixture quality will remain as initially adjusted.

6. Make final adjustments at the high fire position. Set gas adjustor at center of burner air gas ratio stability range or for desired flue gas analysis.

7. Adjust air butterfly valve control linkage for maximum and minimum firing rates and lock.

8. Recheck low fire adjustment.

CAUTION: Operation of combustion equipment can be hazardous resulting in bodily injury or equipment damage. Each burner should be supervised by a combustion safeguard and only qualified personnel should install, make system adjustments and perform any required service.



ORDAN THERMAL PRODUCTS LTD
Combustion Equipment & Controls for Industry
21 Amber St # 9, Markham Ontario Canada L3R 4Z3
Tel: (905) 475-9292 Fax: (905) 475-3286
www.ordanthermal.com

NOTICE: PYRONICS practices a policy of continuous improvement in the design of its products. It reserves the right to change the specifications at any time without prior notice.

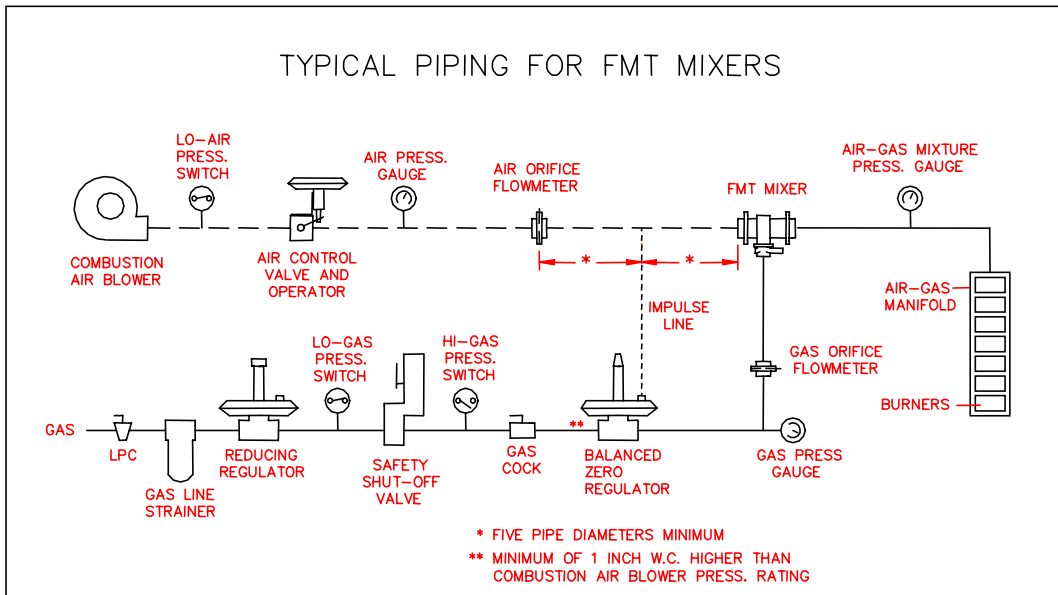

DIMENSIONS

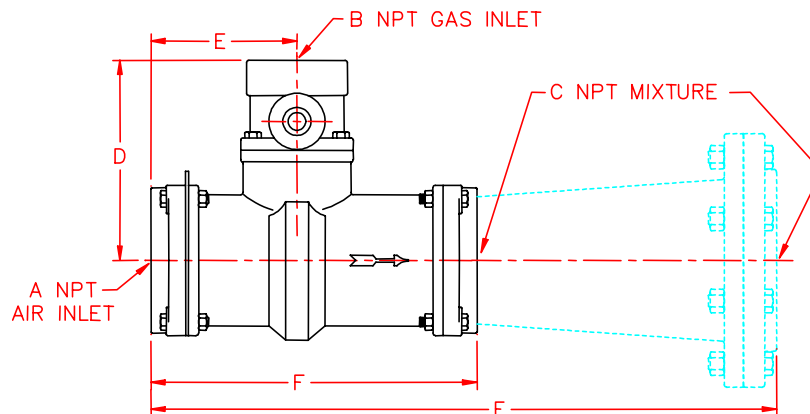

Catalog Number	A	B	C	D	E	F	Weight Lbs.
10 FMT	1-1/4	1	1-1/4	3-13/16	3-7/16	7-5/8	8.5
12 FMT	1-1/2	1	1-1/2	3-13/16	3-5/16	7-9/16	9.5
16 FMT	2	1-1/4	2	4-3/8	3-7/16	7-5/8	12.5
20 FMT	2-1/2	1-1/4	2-1/2	4-15/16	4-3/4	9-1/4	18.0
24 FMT	3	1-1/4	3	4-15/16	4-3/4	9-1/4	16.5
32 FMT	4	2-1/2	4	8	6-1/2	14-1/8	47.5
48 FMT	6	3	6	10-5/8	7-13/16	17-3/8	85.0
4864 FMT	6	3	8	10-5/8	7-13/16	33-3/8	96.0

ORDERING INFORMATION

- Quantity and catalog number of flanged mixing tees.
- Air capacities required in CFH.
- Select balanced regulators from Bulletins 5101 and 5104.
- Select control air valve from Section 1.
- Complete shipping instructions.