

FLOMIXERS SELECTION DATA ALL GASES

MODEL: 2301

Revision: 0

BULLETIN
2301-2311

FLOMIXERS are proportional mixing devices that utilize the energy of a stream of air at pressures up to several pounds to (1) entrain a combustible gas, and (2) to deliver the mixture at unusually high pressure to the burners.

Some advantages incorporated in the design of the Flomixer are:

- (a) Use of Flange connections eliminating unions in gas and air lines.
- (b) Easy accessibility of entrainment insert for inspection, cleaning or changing capacity without disconnecting gas or air lines.
- (c) Universal type Gas Adjuster - good for any kind of gas. Can be sealed if desired.
- (d) Ample pressure test plugs to facilitate checking air pressure, gas suction, and mixture pressure.
- (e) Complete flexibility of right and left - up or down installation without special parts.
- (f) By replacing the combination butterfly flange with pipe flange existing air control valve or gate may be utilized.



COMPLETE FLOMIXER ASSEMBLY

FLOMIXER OPERATION

Referring to the sketch below, Flomixer operation may be described as follows: Air at any available pressure up to 3 psig, controlled by the Butterfly Valve, passes through the Air Sleeve "A" into the Air Jet "B", where it develops the maximum possible velocity. This stream of air moving at high speed creates a suction around it in the Insert "G". This strong suction draws gas from the zero pressure chamber "E" through the Gas Adjuster "D", chamber "C" and Gas Ports "F" into the space around the air stream in Insert "G". The quantity of gas flowing is dependent on the amount of suction, which varies with the air pressure. Once adjustment "D" is set the Flomixer is controlled by using only the Butterfly Valve. The mixture flows into the pressure conversion chamber "H" and is delivered from the outlet flange to the manifold piping and burners.

Complete Flomixer Assemblies consist of the following parts: Butterfly Air Valve, Air Sleeve, Body, Insert, Pipe Flange, Gas Adjuster, Balanced Regulator, Gas Cock, and fittings.

The device is truly a Flow Mixer and, because of refinements in design, will develop higher mixture pressures than usually attainable, and will also maintain accurate gas-air proportions at all air flows if supplied with zero pressure gas. This high capacity characteristic gives the entire combustion system a wider range of operation without requiring higher initial air pressure and reduces sensitivity with regard to burner flow characteristics.

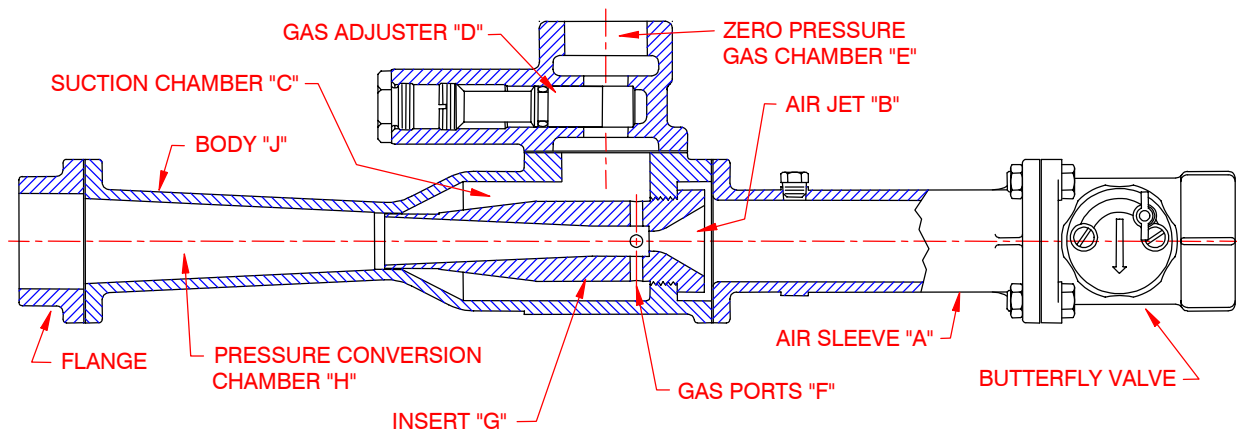

CAUTION: Operation of combustion equipment can be hazardous resulting in bodily injury or equipment damage. Each burner should be supervised by a combustion safeguard and only qualified personnel should install, make system adjustments and perform any required service.



ORDAN THERMAL PRODUCTS LTD
Combustion Equipment & Controls for Industry
21 Amber St # 9, Markham Ontario Canada L3R 4Z3
Tel: (905) 475-9292 Fax: (905) 475-3286
www.ordanthermal.com

NOTICE: PYRONICS practices a policy of continuous improvement in the design of its products. It reserves the right to change the specifications at any time without prior notice.

FLOMIXERS SELECTION DATA ALL GASES

BULLETIN 2301-2304,
2307-2308, 2311
PAGE NO.2



FLOMIXER - EXPLODED VIEW

The photograph above illustrates that flexibility of assembly and interchangeability of parts has been stressed in Flomixer design. All parts in each series are interchangeable.

The Air Sleeve is designed so that it may be removed from the assembly without disturbing any piping, and the Insert can then easily be changed. The following table shows the maximum Insert range for each series. It is recommended, however, that only the Insert sizes specified in the capacity tables be used. If larger Inserts are used, excessive velocity and friction pressure losses in the mixture piping may occur.

Flomixer Series	Outlet Pipe Size	Inserts Min. Max.	Insert Sizes Normal Range
# 88	1"	8 - 12	8 - 12
#1010	1-1/4"	10 - 20	13 - 14
#1210	1-1/2"	10 - 20	15 - 20
#1612	2	20 - 34	21 - 27
#2016	2-1/2"	20 - 34	28 - 32
#2420	3"	32 - 52	34 - 42
#3224	4"	40 - 64	44 - 54

BALANCED REGULATOR (Zero Governor)

Flomixer capacity ratings are based on correct burner to air jet area relations. This normally allows a considerable excess suction in the Flomixer body when the gas adjuster is set for a perfect air-gas ratio. Therefore, a rich mixture can always be maintained if desired and zero governor sizes are selected to permit this.

See Bulletin 5101
for full information
on Zero Regulators.



When Flomixers are used in groups and utilize a single zero governor it is essential, for accurate air-gas proportioning, that the gas pressure at the adjuster inlets be held at zero. This requires not only an accurate zero governor but proper sizing of the gas lines between governor and mixers.

FLOMIXER SELECTION PROCEDURE

Flomixer Selection Tables and similar mixer selection tables list the CFH or BTU per hour capacities based on complete air-gas mixtures (100% aeration). The air capacity of this type mixer is fixed for any given air pressure. Changes in air-gas ratio affect the BTU capacity of the mixer so that operation conditions and burner characteristics must be considered. For example, a Flomixer selected on a 100% primary air basis will deliver 25% more BTU under 80% aeration conditions.

In order to secure satisfactory performance from combinations of burners and Flomixers, it is important that they be correctly matched in capacity or have the correct relationship between the Flomixer air jet and the total effective burner port area. The selection of the proper Flomixer requires information on the type of gas, air and gas pressures, desired air-gas ratio and type of burner as well as the size and arrangement of the air, gas, and mixture manifold piping.

The following general methods and examples for sizing Flomixers have proven satisfactory for most burner applications: (Steps 1 through 4 are required in the selection of all Flomixers).

1. AIR PRESSURE (AT FLOMIXER)

Knowing the air pressure of the combustion air blower or source, air pressure at the Flomixer is computed by deducting flow losses in air piping, valves, fittings, etc. Air capacity = 10 CFH/1000 BTU.

2. MIXTURE PRESSURE (AT FLOMIXER)

Using Table I, pages 5 and 6, mixture pressure is found under the corrected air pressure column. If this pressure falls between columns shown in the table, it can be revised as in the examples.

FLOMIXERS SELECTION DATA ALL GASES

BULLETIN 2301-2304,
2307-2308, 2311
PAGE NO. 3

3. MIXTURE PRESSURE (AT BURNERS)

Deduct 10 to 20% of the mixture pressure at the Flomixer as line loss in the piping between the Flomixer and burners, the amount of loss depending on the length, size, and arrangement of the mixture piping. (Consult velocity pressure and friction loss tables). No valves or variable orifices should be used in the mixture lines.

4. BURNER SELECTION

Using this reduced mixture pressure select the size and number of burners which will give the required heat release. If the desired capacity at this mixture pressure falls between two burners, the larger size is always used. Even with larger burners the total BTU release can be held to a small increase by selecting the Flomixer on the basis of the desired capacity instead of the increased capacity indicated in the burner table. For example, a burner rated at 30% more capacity at the same mixture pressure will actually deliver only 11% more with the correct Flomixer size. It is the Flomixer which really limits the capacity.

5. FLOMIXER SELECTION (Use one of the following methods).

A. Capacity Basis - 100% Aeration

For applications requiring a complete air-gas mixture. Knowing the desired BTU capacity and the type of fuel gas, the Flomixer is selected directly from Table 1 on pages 5 and 6 under the air pressure column computed in Step 1. If the corrected air pressure falls between listed air pressures, the selection procedure is changed as follows:

$$\text{"BTU Capacity"} \times \sqrt{\frac{\text{Air Pressure (Table)}}{\text{Air Pressure (Actual)}}} = \text{"Selection Capacity"}$$

B. Capacity Basis - Less than 100% Aeration

For applications where less than 100% primary air mixtures are required (F.R., Sticktite and Blast Tip burners). Knowing the desired BTU capacity and percentage aeration, a new Flomixer "Selection Capacity" is computed. Multiplying the BTU capacity by the aeration percentage gives the new figure. (Multiplier for 80% aeration is 0.80). Using this new figure, the Flomixer is selected from Table 1 under the air pressure column computed in Step 1 or from a corrected capacity figure as shown in 5A above.

C. Burner Area Basis

Knowing the number, size, and type of burners required (Step 4), determine the total port area and correct this area for burner discharge coefficient. Using Table 2 on page 5, divide burner area by Discharge Factor.

When burners and Flomixers are matched on the area relationship basis, capacities shown in the Flomixer table are for complete air-gas mixtures. For operation at other air-gas ratios, the corrected burner area should be multiplied by the aeration percentage (see paragraph 5B) before selecting the Flomixers.

This new "Burner Area" is then used to select the proper Flomixer from Table 1 on pages 5 and 6 under the proper air pressure and fuel gas columns.

D. Capacity Basis - Low Mixture Pressures.

For burners operating with low mixture pressures, the Flomixer capacities are higher than listed in Table 1. Knowing the air pressure, type of gas and total BTU per hour to be supplied to one or more burners, the actual burner capacity is re-figured to get a new "Selection Capacity". Under the proper air pressure column of Table 4, page 7, select the desired operating mixture pressure. The figure to the right under Column (J) is the "Capacity Multiplier" and is used as follows:

$$\frac{\text{"Burner Capacity"}}{\text{"Capacity Multiplier"}} = \text{"Selection Capacity"}$$

Corrections for air-gas ratio should be applied to the "Selection Capacity" as computed in 5B, before selecting the Flomixer.

The "Selection Capacity", which is always smaller than the original "Burner Capacity", is used to select the Flomixer under the proper air pressure and gas columns in the Flomixer Selection Table 1.

EXAMPLES

PYRONICS BURNER - FLOMIXER SELECTION ON CAPACITY BASIS - 100% AERATION

Required BTU - 1,850,000/hr.
Aeration - 100% Primary Air
Type of gas - Natural
Type of burners - totally enclosed - Pyronics
Tunnel Burner
Number of burners - 5
Air Pressure - 16 osi

1. Calculated air piping loss = 2 osi
16 osi - 2 osi = 14 osi Air Pressure at Flomixer

CAUTION: Operation of combustion equipment can be hazardous resulting in bodily injury or equipment damage. Each burner should be supervised by a combustion safeguard and only qualified personnel should install, make system adjustments and perform any required service.



ORDAN THERMAL PRODUCTS LTD
Combustion Equipment & Controls for Industry
21 Amber St # 9, Markham Ontario Canada L3R 4Z3
Tel: (905) 475-9292 Fax: (905) 475-3286
www.ordanthermal.com

NOTICE: PYRONICS practices a policy of continuous improvement in the design of its products. It reserves the right to change the specifications at any time without prior notice.

FLOMIXERS SELECTION DATA ALL GASES

BULLETIN 2301-2304,
2307-2308, 2311
PAGE NO. 4

2. From Flomixer Selection Table I, mixture pressure with 16 osi air is 11" w. c. Use Table 3 or calculate as follows:

$$\begin{aligned} &\text{Mixture Pressure at 14 osi} = \\ &11.0" \times \frac{14 \text{ osi (Actual Air Pressure)}}{16 \text{ osi (Air Pressure Table)}} = \\ &9.6" \text{ w. c. (At Flomixer)} \end{aligned}$$

3. The mixture piping loss is assumed to be 15%.

$$9.6" \times (1.00 - 0.15) = 8.2" \text{ w.c. mixture pressure at burners.}$$

$$4. \frac{1,850,000 \text{ BTU}}{5 \text{ burners}} = 370,000$$

(Minimum Capacity per burner)

From Bulletin 3301, page 2, select #162-10 Pyronics Tunnel Burners.

5A. To select the proper Flomixer the capacity at 14 osi air pressure should be adjusted to an equivalent capacity at 16 osi since the selection table does not list capacities at 14 osi.

$$1,850,000 \text{ BTU (Desired Capacity)} \times \sqrt{\frac{16 \text{ osi (Table)}}{14 \text{ osi (Actual)}}} =$$

1,980,000 BTU (Selection Capacity)

No correction is required for a change in air-gas ratio since the Pyronics burners will be operated with 100% primary air.

An input of 1,980,000 BTU/hr. with 16 osi air falls between a #3216-48 and #3216-50 (Table 1). The smaller insert size should always be used when the capacity desired falls between two sizes.

One - #3216-48 Flomixer is required.

F.R. NOZZLE - FLOMIXER SELECTION ON CAPACITY BASIS - 80% AERATION

Required BTU - 2,250,000/hr.
Aeration - 80%
Type of gas - Propane
Type of burners - Flame Retention
Type (F.R. Nozzles. Discharge
Coefficient - 0.75)
Number of burners - 6
Air Pressure - 12 osi (at Flomixer)

1. Air Pressure - 12 osi at Flomixer.

2. At 12 osi air pressure, the mixture pressure is 8.2" w.c. (Table 3).

3. Mixture manifold velocity and friction pressure losses computed as 1.2" w.c.

$$8.2" - 1.2" = 7.0" \text{ Mixture Pressure at the burners.}$$

$$4. \frac{2,250,000 \text{ BTU}}{6 \text{ burners}} = 375,000 \text{ BTU}$$

(Capacity per burner)

From Bulletin 3102, page 1, select #12 F.R. Nozzles.

5B. With required "Burner Capacity" of 2,250,000 BTU and 80% primary air, the "Selection Capacity" is computed as follows:

$$2,250,000 \text{ BTU} \times 0.80 = 1,800,000 \text{ BTU}$$

(Selection Capacity)

From Table 1 select #3216-50 Flomixer.

ALTERNATE SELECTION OF FLOMIXER ON BURNER AREA BASIS (See Steps 1-4 Above)

5C. Port area of each #12 F.R. Nozzle is 1.059 sq. in. (Bulletin 3102, page 2).

$$6 \text{ nozzles} \times 1.059 \text{ sq. in.} = 6.35 \text{ sq. in.}$$

Correct burner area for 0.75 discharge coefficient - (Table 2 on page 5).

$$\frac{6.35}{1.2} = 5.29 \text{ sq. in.}$$

A selection based on 5.29 sq. in. is correct for 100% aeration. The "Selection Area" at less than full premix is:

$$5.29 \text{ sq. in.} \times 80\% \text{ aeration} = 4.23 \text{ sq. in.}$$

(Selection Area)

Using the Minimum Burner Area Column of Selection Table 1, a #3216-50 is picked for Propane Gas.

FLOMIXERS SELECTION DATA ALL GASES

BULLETIN 2301-2304,
2307-2308, 2311
PAGE NO.5

The Flomixer is a mixer which responds to all of the varying forces exerted upon it, (air and gas pressures, piping, effective burner areas, back pressures, etc.). Since the capacity is in equilibrium with the

other variables, any change in one will cause a corresponding change in the others. The Flomixer, because of its advanced design, will give superior performance if used within the limits of normal operation.

TABLE 2 - CORRECTION FACTORS FOR VARIOUS TYPES OF BURNERS

Type of Burner	Pepper Box or Multiple Port Burners	Flame Retaining, or Piloted Burners, Blast Tips	Annular or Single Port Type Round or Flat Nosed Tunnel Burner	Venturi Type Steel Tunnel Burners
Approximate Coefficient of Discharge	0.45 to 0.65	0.65 to 0.75	0.75 to 0.95	1.00 to 1.20
Factor	2.0 to 1.4	1.4 to 1.2	1.2 to 1.0	0.90 to 0.75

TABLE 3 - MIXTURE PRESSURE DEVELOPED BY FLOMIXERS AT VARIOUS AIR PRESSURES

Air Pressure psi	2	4	6	8	10	12	14	16	18	20	22	24	26	28	30	32
Mixture Pressures Inches W.C.	1.4	2.8	4.1	5.5	6.9	8.2	9.6	11.0	12.4	13.8	15.2	16.5	17.9	19.2	20.6	22.0

CAUTION: Operation of combustion equipment can be hazardous resulting in bodily injury or equipment damage. Each burner should be supervised by a combustion safeguard and only qualified personnel should install, make system adjustments and perform any required service.



ORDAN THERMAL PRODUCTS LTD
Combustion Equipment & Controls for Industry
21 Amber St # 9, Markham Ontario Canada L3R 4Z3
Tel: (905) 475-9292 Fax: (905) 475-3286
www.ordanthermal.com

NOTICE: PYRONICS practices a policy of continuous improvement in the design of its products. It reserves the right to change the specifications at any time without prior notice.

FLOMIXERS SELECTION DATA ALL GASES

BULLETIN 2301-2304,
2307-2308, 2311
PAGE NO.6

TABLE 1 - FLOMIXER SELECTION Based on 100% Primary Air

CAPACITIES in 1000's Btu/Hr.								Minimum Burner Area, Sq. Inches, With 0.9 Coefficient of Discharge	FLOMIXER CATALOG NUMBERS
4 osi to 32 osi Air Pressure									
4 osi	8 osi	12 osi	16 osi	20 osi	24 osi	28 osi	32 osi		
Maximum Mixture Pressure, Inches W.C.									
2.8	5.5	8.2	11	13.6	16.5	19.2	22		
25	35	43	50	56	61	66	71	0.107	88-8
33	47	57	66	74	81	87	93	0.146	88-9
40	57	69	80	89	98	106	113	0.167	88-10
50	71	87	100	112	122	132	141	0.203	88-11
60	85	104	120	134	147	159	170	0.243	88-12
70	99	121	140	157	171	185	198	0.275	1010-13
83	117	144	166	186	203	220	235	0.331	1010-14
93	132	161	186	208	228	246	263	0.378	1210-15
108	153	187	216	241	265	286	305	0.433	1210-16
120	170	208	240	268	294	317	339	0.467	1210-17
135	191	234	270	302	331	357	382	0.546	1210-18
150	212	260	300	335	367	397	424	0.610	1210-19
168	238	291	336	376	412	444	475	0.678	1210-20
183	259	317	366	409	448	484	518	0.743	1612-21
200	283	346	400	447	490	529	566	0.816	1612-22
220	311	381	440	492	539	582	622	0.891	1612-23
240	339	416	480	537	588	635	679	0.973	1612-24
260	368	450	520	581	637	688	735	1.050	1612-25
280	396	485	560	626	686	741	792	1.140	1612-26
303	429	525	606	678	742	802	857	1.230	1612-27
325	460	563	650	727	796	860	919	1.320	2016-28
350	495	606	700	783	857	926	990	1.420	2016-29
375	530	650	750	839	919	992	1061	1.520	2016-30
400	566	693	800	894	980	1058	1131	1.620	2016-31
425	601	736	850	950	1041	1124	1202	1.730	2016-32
480	679	831	960	1073	1176	1270	1358	1.930	2420-34
540	764	935	1080	1207	1323	1429	1527	2.190	2420-36
600	849	1039	1200	1342	1470	1587	1697	2.430	2420-38
670	948	1160	1340	1498	1641	1773	1895	2.700	2420-40
735	1039	1273	1470	1644	1800	1945	2079	2.980	2420-42
805	1138	1394	1610	1800	1972	2130	2277	3.260	3224-44
885	1252	1533	1770	1979	2168	2341	2503	3.570	3224-46
960	1358	1663	1920	2147	2352	2540	2715	3.860	3224-48
1040	1471	1801	2080	2326	2547	2752	2942	4.220	3224-50
1125	1591	1949	2250	2516	2756	2976	3182	4.550	3224-52
1210	1711	2096	2420	2706	2964	3201	3422	4.920	3224-54
1300	1838	2252	2600	2907	3184	3439	3677	5.290	3224-56
1395	1973	2416	2790	3119	3417	3691	3946	5.670	3224-58
1490	2107	2581	2980	3332	3650	3942	4214	6.070	3224-60
1590	2249	2754	3180	3555	3895	4207	4497	6.480	3224-62
1700	2404	2944	3400	3801	4164	4498	4808	6.910	3224-64

Note: The discharge pipe size of Flomixers with inserts larger than #54 should be expanded to 6" before connection to a manifold.

FLOMIXERS SELECTION DATA ALL GASES

BULLETIN 2301-2304,
2307-2308, 2311
PAGE NO. 7

TABLE 4 - AREA AND CAPACITY MULTIPLIER

AIR PRESSURE	4 osi (A)	8 osi (B)	12 osi (C)	16 osi (D)	20 osi (E)	24 osi (F)	28 osi (G)	32 osi (H)	Capacity Multiplier (J)	Burner Area Multiplier (K)
Original Mixture Pressure Inches W.C.	2.8	5.5	8.2	11.0	13.8	16.5	19.2	22.0	1.00	1.00
New Mixture Pressure Inches W.C.	2.50	5.00	7.50	10.00	12.50	15.00	17.50	20.00	1.03	1.08
	2.30	4.50	6.80	9.00	11.30	13.50	15.80	18.00	1.07	1.18
	2.00	4.00	6.00	8.00	10.00	12.00	14.00	16.00	1.11	1.30
	1.80	3.50	5.30	7.00	8.80	10.50	12.30	14.00	1.14	1.42
	1.50	3.00	4.50	6.00	7.50	9.00	10.50	12.00	1.18	1.60
	1.30	2.50	3.80	5.00	6.30	7.50	8.80	10.00	1.21	1.79
	1.00	2.00	3.00	4.00	5.00	6.00	7.00	8.00	1.24	2.06
	0.75	1.50	2.30	3.00	3.80	4.50	5.30	6.00	1.27	2.45
	0.50	1.00	1.50	2.00	2.50	3.00	3.50	4.00	1.30	3.05
	0.25	1.50	0.75	1.00	1.25	1.50	1.75	2.00	1.33	4.42
	0.13	0.25	0.38	0.50	0.63	0.75	0.88	1.00	1.35	6.34
	0.05	0.10	0.15	0.20	0.25	0.30	0.35	0.40	1.36	12.10
	0.03	0.05	0.08	0.10	0.13	0.15	0.18	0.20	1.36	14.30

A. FLOMIXER CAPACITIES AT OTHER THAN 100% AERATION

Capacity at other than 100% Aeration =

$$\frac{\text{Capacity at 100\% Aeration}}{\% \text{ Aeration}}$$

B. TO FIND BURNER AREA REQUIRED TO PRODUCE LOWER MIXTURE PRESSURE FOR GIVEN AIR PRESSURE (WITH SAME FLOMIXER)

1. Under Air Pressure column of Area and Capacity Multiplier Table 4, select New Mixture Pressure desired.
2. Pick Area and Capacity Multipliers (Columns "J" and "K").
3. Multiply Burner area of Flomixer Selection Table 1 by "Area Multiplier" to get new burner area.

EXAMPLE

Air Pressure 16 osi
Original Mixture 11" w.c.
New Mixture Pressure = 0.5" w.c.

SOLUTION

Under column "D" find 0.5" w.c. mixture pressure and pick Area Multiplier of 6.34 and Capacity Multiplier 1.35 (Columns "K" and "J").

C. TO DETERMINE THE EFFECT OF INCREASED BURNER AREA ON CAPACITY AND MIXTURE PRESSURE

1. Obtain Burner Area Multiplier: New burner area divided by original area (from Flomixer Selection Table).
2. Locate this multiplier in column "K" of Table 4. Corresponding figure in column "J" in the Capacity Multiplier.
3. New Mixture Pressure will be found on same line to left under correct air pressure column.

CAUTION: Operation of combustion equipment can be hazardous resulting in bodily injury or equipment damage. Each burner should be supervised by a combustion safeguard and only qualified personnel should install, make system adjustments and perform any required service.



ORDAN THERMAL PRODUCTS LTD
Combustion Equipment & Controls for Industry
21 Amber St # 9, Markham Ontario Canada L3R 4Z3
Tel: (905) 475-9292 Fax: (905) 475-3286
www.ordanthermal.com

NOTICE: PYRONICS practices a policy of continuous improvement in the design of its products. It reserves the right to change the specifications at any time without prior notice.

FLOMIXERS SELECTION DATA ALL GASES

BULLETIN 2301-2304,
2307-2308, 2311
PAGE NO.8

EXAMPLE

12 osi Air
Original Mixture Pressure = 8.2" w.c.
Original Burner Area - 1.0 sq. in.
New Burner Area - 1.6 sq. in.

SOLUTION

$$\text{"Area Multiplier"} = \frac{\text{New Burner Area}}{\text{Original Burner Area}} = \frac{1.6 \text{ sq. in.}}{1.0 \text{ sq. in.}}$$

= 1.6

Under Column "K" find 1.6. Corresponding Capacity Multiplier (Column "J") is 1.18 and new Mixture Pressure is 4.5" w.c. (Column "C").

D. TO DETERMINE BURNER AREA REQUIRED TO INCREASE CAPACITY AND REDUCE MIXTURE PRESSURE (WITH SAME FLOMIXER)

1. Determine Capacity Multiplier: New capacity divided by original capacity (Table 1).

2. Locate this Capacity Multiplier in column "J" and corresponding Burner Area Multiplier in column "K".

3. New Mixture Pressure will be found on same line to left under correct air pressure column.

EXAMPLE

Air Pressure 32 osi
Original Capacity 200,000 BTU/hr.
New Capacity 270,000 BTU/hr.
Original Mixture Pressure 22" w.c.

SOLUTION

$$\text{Capacity Multiplier} = \frac{270,000}{200,000} = 1.35$$

Under Column "J" find 1.35. Area Multiplier is 6.34 (Column "K") and New Mixture Pressure is 1.0" w.c. (Column "H").

FLOMIXER SERIES 1 - DIMENSIONS

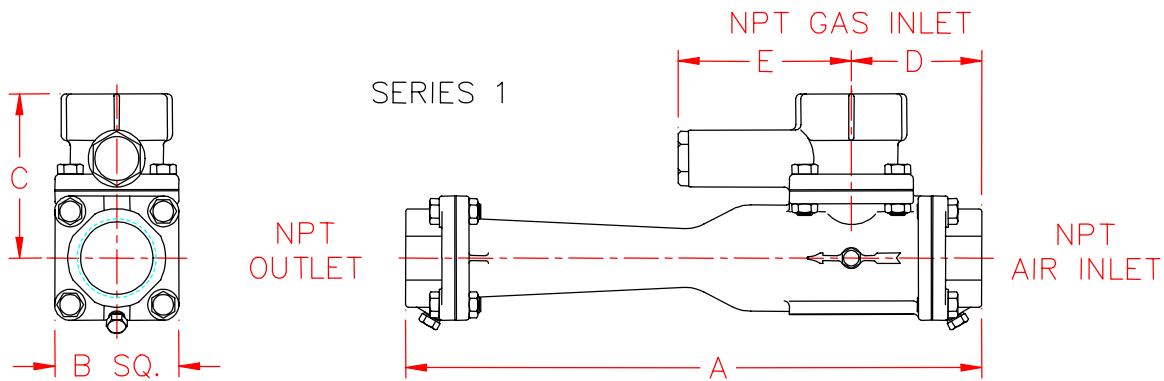

Flomixer Series 1 Model Numbers	Outlet Pipe Size NPT	Inlet Gas Pipe Size NPT	Inlet Air Pipe Size NPT	A	B	C	D	E	Approx. Weight Lbs.
88-1	1	1	1	9-5/8	2-3/8	3-1/8	2-1/4	3-3/8	6.3
1010-1	1-1/4	1-1/4	1-1/4	14	3	4	3-1/8	4-1/4	12.7
1210-1	1-1/2	1-1/4	1-1/2	14	3	4	3-1/8	4-1/4	12.7
1612-1	2	1-1/2	2	15-1/2	3-1/2	4-1/2	3-5/8	4-1/4	18.7
2016-1	2-1/2	2	2-1/2	18-5/8	4	5-5/8	3-7/8	4-1/2	25.8
2420-1	3	2-1/2	3	22-1/8	4-3/8	6-1/2	4-3/4	5-7/8	36.4
3224-1	4	3	4	26-1/4	6	8	5-5/8	6-3/4	52.3

Note: All dimensions are in inches.

FLOMIXERS SELECTION DATA ALL GASES

BULLETIN 2301-2304,
2307-2308, 2311
PAGE NO.9

FLOMIXER SERIES 2 - DIMENSIONS

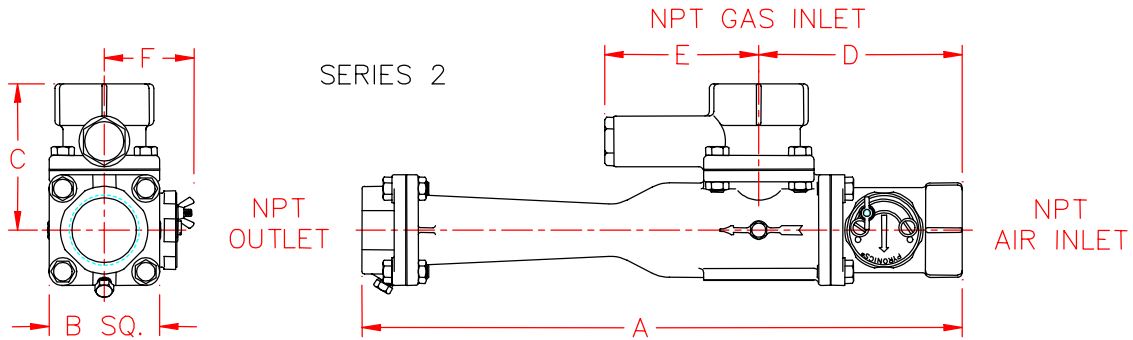

Flomixer Series 2 Model Numbers	Outlet Pipe Size NPT	Inlet Gas Pipe Size NPT	Inlet Air Pipe Size NPT	A	B	C	D	E	F	Approx. Weight Lbs.
88-2	1	1	1	12-1/4	2-3/8	3	4-7/8	3-3/8	2-1/4	8.0
1010-2	1-1/4	1-1/4	1-1/4	16-3/8	3	4	5-1/2	4-1/4	2-1/2	15.5
1210-2	1-1/2	1-1/4	1-1/2	16-3/8	3	4	5-1/2	4-1/4	2-1/2	15.5
1612-2	2	1-1/2	2	18	3-1/2	4-1/2	6-1/8	4-1/4	2-3/4	21.8
2016-2	2-1/2	2	2-1/2	21-1/2	4	5-5/8	6-7/8	4-1/2	3-1/8	31.6
2420-2	3	2-1/2	3	25	4-3/8	6-1/2	7-5/8	5-7/8	3-3/8	42.7
3224-2	4	3	4	29-3/8	6	8	8-3/4	6-3/4	3-7/8	64.2

FLOMIXER SERIES 3 - DIMENSIONS

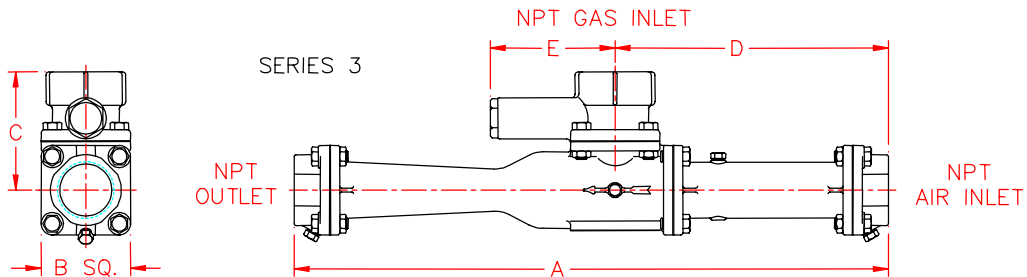

Flomixer Series 3 Model Numbers	Outlet Pipe Size NPT	Inlet Gas Pipe Size NPT	Inlet Air Pipe Size NPT	A	B	C	D	E	Approx. Weight Lbs.
88-3	1	1	1	13-7/8	2-3/8	3-1/8	6-1/2	3-3/8	7.7
1010-3	1-1/4	1-1/4	1-1/4	20	3	4	9-1/4	4-1/4	13.7
1210-3	1-1/2	1-1/4	1-1/2	20	3	4	9-1/4	4-1/4	13.7
1612-3	2	1-1/2	2	24-3/4	3-1/2	4-1/2	12-7/8	4-1/4	23.8
2016-3	2-1/2	2	2-1/2	28-1/8	4	5-5/8	13-1/2	4-1/2	32.3
2420-3	3	2-1/2	3	33-5/8	4-3/8	6-1/2	16-3/8	5-7/8	46.8
3224-3	4	3	4	39-3/4	6	8	19-1/8	6-3/4	71.4

CAUTION: Operation of combustion equipment can be hazardous resulting in bodily injury or equipment damage. Each burner should be supervised by a combustion safeguard and only qualified personnel should install, make system adjustments and perform any required service.



ORDAN THERMAL PRODUCTS LTD
Combustion Equipment & Controls for Industry
21 Amber St # 9, Markham Ontario Canada L3R 4Z3
Tel: (905) 475-9292 Fax: (905) 475-3286
www.ordanthermal.com

NOTICE: PYRONICS practices a policy of continuous improvement in the design of its products. It reserves the right to change the specifications at any time without prior notice.

FLOMIXERS SELECTION DATA ALL GASES

BULLETIN 2301-2304,
2307-2308, 2311
PAGE NO. 10

FLOMIXER SERIES 4 - DIMENSIONS

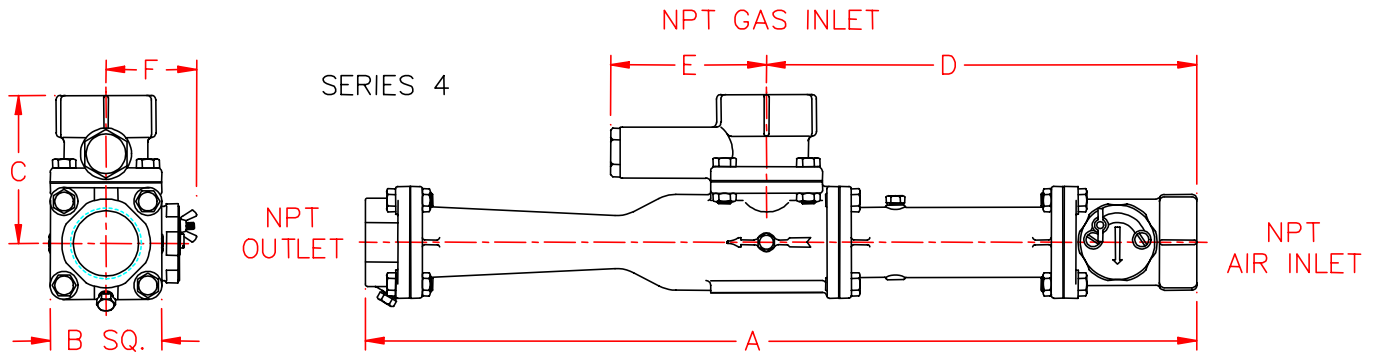

Flomixer Series 4 Model Numbers	Outlet Pipe Size NPT	Inlet Gas Pipe Size NPT	Inlet Air Pipe Size NPT	A	B	C	D	E	F	Approx. Weight Lbs.
88-4	1	1	1	16-1/2	2-3/8	3-1/8	9-1/8	3-3/8	2-1/4	9.4
1010-4	1-1/4	1-1/4	1-1/4	22-3/8	3	4	11-5/8	4-1/4	2-1/2	16.5
1210-4	1-1/2	1-1/4	1-1/2	22-3/8	3	4	11-5/8	4-1/4	2-1/2	16.5
1612-4	2	1-1/2	2	27-1/4	3-1/2	4-1/2	15-1/2	4-1/4	2-3/4	26.9
2016-4	2-1/2	2	2-1/2	31	4	5-5/8	16-3/8	4-1/2	3-1/8	38.1
2420-4	3	2-1/2	3	36-1/2	4-3/8	6-1/2	19-1/4	5-7/8	3-3/8	53.1
3224-4	4	3	4	42-7/8	6	8	22-3/8	6-3/4	3-7/8	83.3

FLOMIXERS SELECTION DATA ALL GASES

BULLETIN 2301-2304,
2307-2308, 2311
PAGE NO. 11

FLOMIXER SERIES 7 - DIMENSIONS

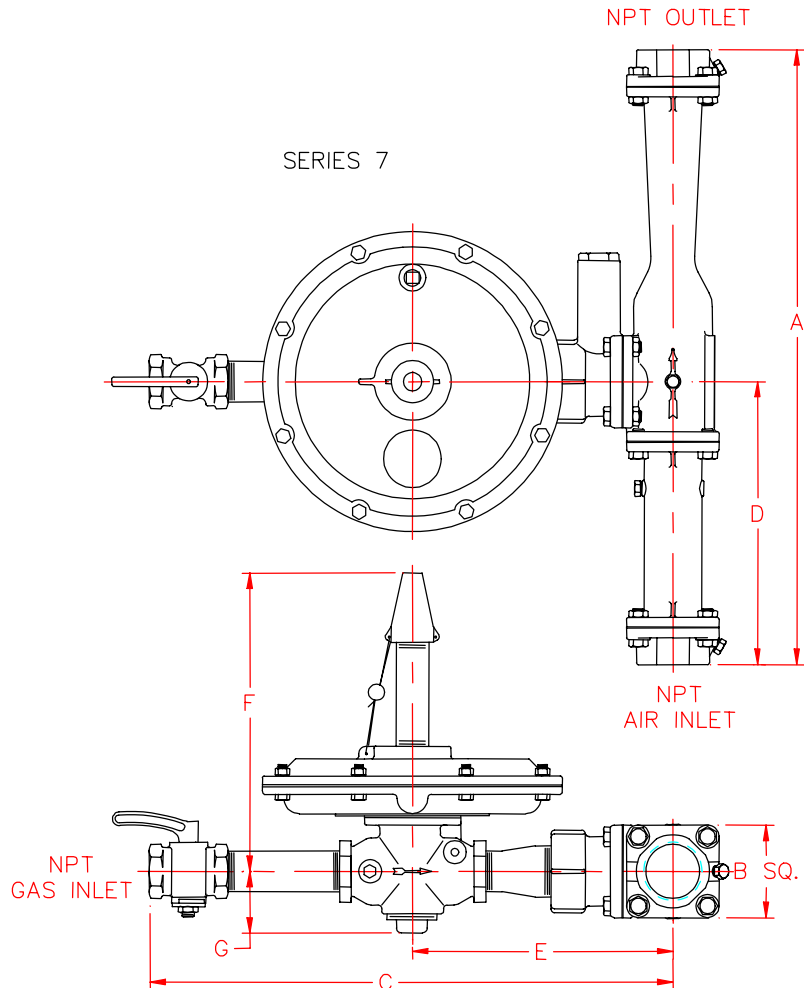

Flomixer Series 7 Model Numbers	Outlet Pipe Size NPT	Inlet Gas Pipe Size NPT	Inlet Air Pipe Size NPT	A	B	C	D	E	F	G	Approx. Weight Lbs.
88-7	1	3/4	1	13-7/8	2-3/8	14-7/8	6-1/2	7-3/8	9-1/4	2	15.5
1010-7	1-1/4	1	1-1/4	20	3	17	9-1/4	8-1/2	9-3/4	2	24.7
1210-7	1-1/2	1	1-1/2	20	3	17	9-1/4	8-1/2	9-3/4	2	24.7
1612-7	2	1-1/2	2	24-3/4	3-1/2	23-5/8	12-7/8	11-5/8	12-1/2	3-1/4	43.6
2016-7	2-1/2	1-1/2	2-1/2	28-1/8	4	24-1/4	13-3/8	12-1/4	12-1/2	3-1/4	52.4
2420-7	3	2-1/2	3	33-5/8	4-3/8	29-1/2	16-1/4	15-3/4	14	3-5/8	121.0
3224-7	4	2-1/2	4	39-3/4	6	32-1/2	19-1/8	18-3/4	14	3-5/8	146.8

CAUTION: Operation of combustion equipment can be hazardous resulting in bodily injury or equipment damage. Each burner should be supervised by a combustion safeguard and only qualified personnel should install, make system adjustments and perform any required service.



ORDAN THERMAL PRODUCTS LTD
Combustion Equipment & Controls for Industry
21 Amber St # 9, Markham Ontario Canada L3R 4Z3
Tel: (905) 475-9292 Fax: (905) 475-3286
www.ordanthermal.com

NOTICE: PYRONICS practices a policy of continuous improvement in the design of its products. It reserves the right to change the specifications at any time without prior notice.

FLOMIXERS

SELECTION DATA

ALL GASES

BULLETIN 2301-2304,
2307-2308, 2311
PAGE NO. 12

FLOMIXER SERIES 8 - DIMENSIONS

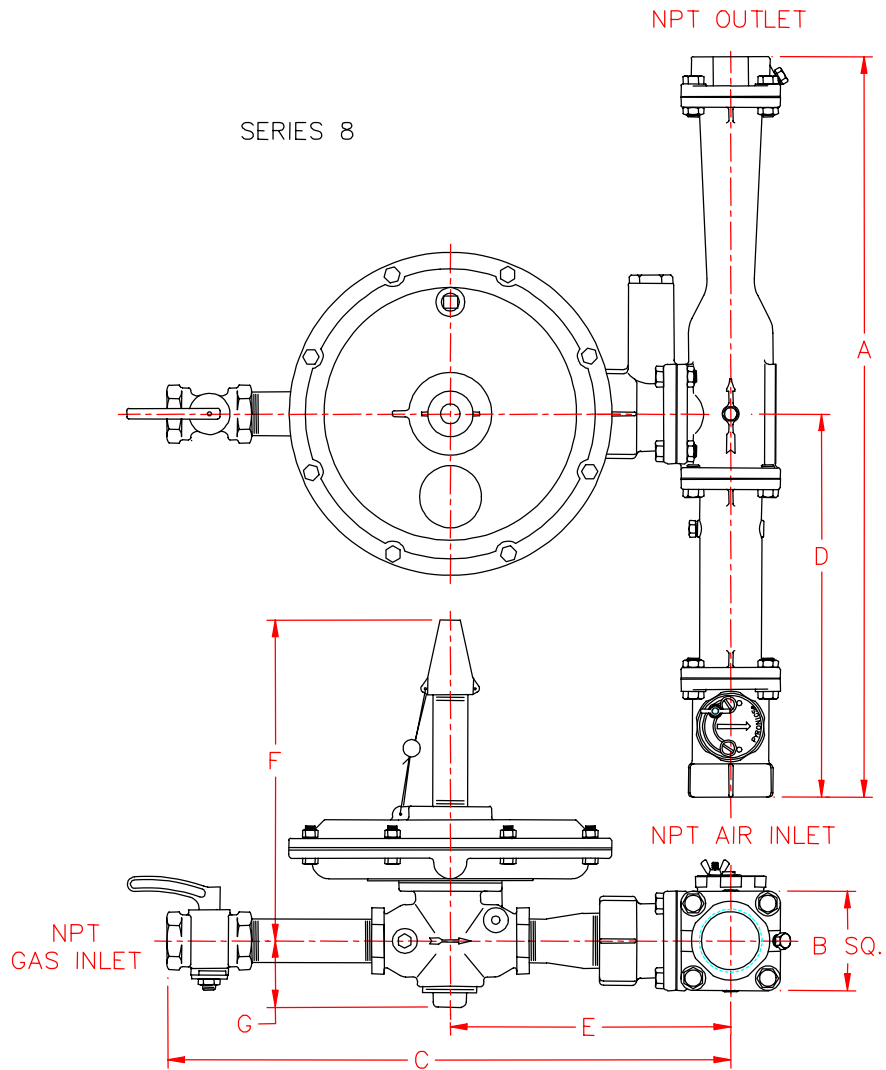

Flomixer Series 8 Model Numbers	Outlet Pipe Size NPT	Inlet Gas Pipe Size NPT	Inlet Air Pipe Size NPT	A	B	C	D	E	F	G	Approx. Weight Lbs.
88-8	1	3/4	1	16-1/2	2-3/8	14-7/8	9-1/8	7-3/8	9-1/4	2	17.3
1010-8	1-1/4	1	1-1/4	22-3/8	3	17	11-5/8	8-1/2	9-3/4	2	27.5
1210-8	1-1/2	1	1-1/2	22-3/8	3	17	11-5/8	8-1/2	9-3/4	2	27.5
1612-8	2	1-1/2	2	27-1/4	3-1/2	23-5/8	15-1/2	11-5/8	12-1/2	3-1/4	46.7
2016-8	2-1/2	1-1/2	2-1/2	31	4	24-1/4	16-3/8	12-1/4	12-1/2	3-1/4	58.2
2420-8	3	2-1/2	3	36-1/2	4-3/8	29-1/2	19-1/8	15-3/4	14	3-5/8	127.3
3224-8	4	2-1/2	4	42-7/8	6	32-1/2	22-1/4	18-3/4	14	3-5/8	158.7