

# HIGH BLAST MIXERS

MODEL: 2381 - HB

Revision: 0

BULLETIN  
2381

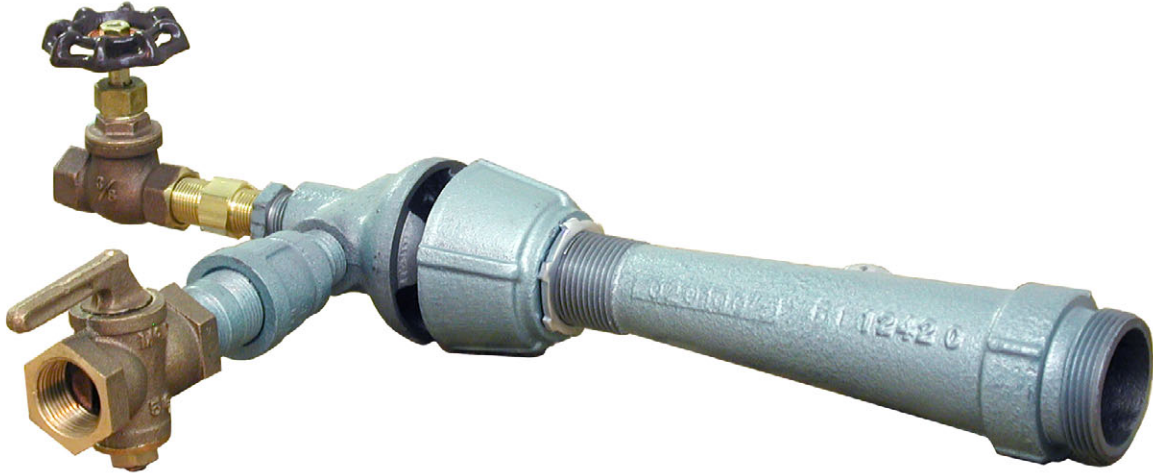

#12HB HIGH BLAST MIXER

## OPERATION

High Blast Mixers are compact air/gas mixers used in installations where high pressure air is available. These economical units are ideally suited to manual control operation for a wide range of heating applications where low pressure air is not available.

High Blast Mixers use small amounts of high pressure air (approximately 10%) to pickup incoming gas at the mixer.

Air at 20 to 100 psig is passed through a primary modified venturi which inspirates an equal amount of gas and elevates its pressure. The resultant mixture of one part air and one part gas is delivered to

the main orifice at approximately 40% of the inlet air pressure.

The Hijector (the main venturi of the High Blast Mixer) efficiently entrains large quantities of combustion air and delivers the mixture to the burner system. The mixture produces a hard, sharp, clear blue, typical blast flame. The high pressure air valve and primary air shutter provide for wide ranges of adjustment.

Injector type design of high pressure stage prevents air feed back into the gas line. Capacities listed in the table are for 90% primary air and may be increased where adequate secondary is available.

## CAPACITY TABLE

Catalog Number	Minimum Burner Area Sq. Inches	Gas in 1000's Btu/Hr. and Air in CFM											
		Air Pressure, psig											
		20		40		60		80		100		120	
		Average Mixture Pressure, Inches W.C.											
		2.5"		5"		7.5"		10"		12.5"		15"	
Gas	Air	Gas	Air	Gas	Air	Gas	Air	Gas	Air	Gas	Air	Gas	Air
6HB	0.19	40	0.8	55	1.2	68	1.5	80	1.7	87	1.9	95	2.1
8HB	0.30	65	1.8	90	2.4	110	3.0	125	3.4	140	3.8	156	4.2
10HB	0.67	145	3.9	205	5.5	250	6.8	290	7.8	325	8.7	355	9.5
12HB	1.06	230	5.3	320	7.3	395	9.0	450	10.4	500	11.5	555	12.6
16HB	1.85	400	7.1	565	10.0	700	12.3	800	14.2	880	15.8	980	17.3
20HB	2.49	550	9.8	770	13.8	950	17.0	1100	19.6	1220	21.8	1330	24.0
24HB	3.25	680	12.3	960	17.3	1180	21.4	1360	24.6	1520	27.4	1660	30.0
32HB	5.54	1200	20.5	1690	28.8	2080	35.6	2400	41.0	2680	45.5	2920	49.8

CAUTION: Operation of combustion equipment can be hazardous resulting in bodily injury or equipment damage. Each burner should be supervised by a combustion safeguard and only qualified personnel should install, make system adjustments and perform any required service.



**ORDAN THERMAL PRODUCTS LTD**  
Combustion Equipment & Controls for Industry  
21 Amber St # 9, Markham Ontario Canada L3R 4Z3  
Tel: (905) 475-9292 Fax: (905) 475-3286  
[www.ordanthermal.com](http://www.ordanthermal.com)

NOTICE: PYRONICS practices a policy of continuous improvement in the design of its products. It reserves the right to change the specifications at any time without prior notice.

# HIGH BLAST MIXERS

BULLETIN  
2381  
PAGE NO.2

## DIMENSIONS

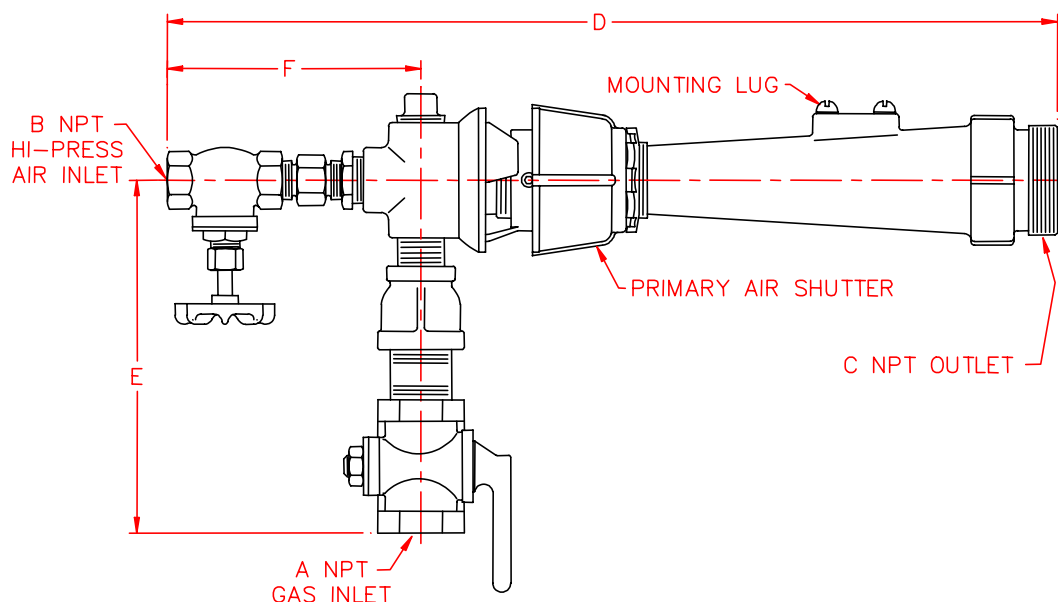

Catalog Number	A	B	C	D	E	F	Weight Lbs.
6HB	1/2	3/8	3/4	10-1/16	5-3/8	4-1/16	4.00
8HB	1/2	3/8	1	11-7/8	5-3/8	4-1/16	5.00
10HB	3/4	3/8	1-1/4	14-1/2	6-1/8	4-7/16	6.25
12HB	3/4	3/8	1-1/2	15-1/2	6-1/8	4-7/16	7.75
16HB	1	3/8	2	19-1/4	7-3/16	4-13/16	15.00
20HB	1	3/8	2-1/2	22-3/16	7-3/16	4-13/16	18.00
24HB	1-1/4	3/8	3	26-7/16	8-5/8	5-1/8	26.00
32HB	1-1/2	3/8	4	32-5/16	9-11/16	5-5/16	42.50

Note: All dimensions are in inches.

### INSTALLATION

1. Make high pressure air and gas connections. These may be pipe or flexible hoses.
2. The connections should not be smaller than the valve sizes.
3. Minimum gas pressures: Manufactured 5" w.c.; Mixed 3" w.c.; Natural, Propane or Butane 1" w.c.
4. Check air and gas lines for leaks.

### ADJUSTMENT

1. Loosen locknut on body and open primary air shutter wide.
2. Open high pressure air valve.
3. Light pilot or hold lighting torch alongside burners and slowly open gas cock.
4. After flame is lighted, flame character is adjusted by the setting of the gas cock.
5. Opening gas wider gives a softer, longer flame. Closing it

slightly produces a sharper, shorter flame.

6. To shut off torch, close gas valve first and then air valve.

### ORDERING INFORMATION

Please include the following information for each size High Blast Mixer ordered:

1. Number required and size.
2. HB assemblies include both air globe valve and gas cock. State if these are not required.
3. Kind of gas and available pressure.
4. Air pressure available.
5. Shipping instructions.

If in doubt about High Blast Mixer selection or use, send full details of the application so we may assist you.