

BURNERS HI-VELOCITY SINGLE TUNNEL

MODEL: 3505 - HS - GA - R
3505 - HS - F - R

Revision: 0

BULLETIN
3505

DESCRIPTION

The Hot Shot (HS) series is a nozzle-mixing, hi-velocity burner used primarily where a high recirculation rate of the products of combustion is required. The produce a hi-velocity stream of hot gases at the exit of the burner tunnel which will give a high degree of heat penetration into the work in a furnace. The result being greater efficiency with reduced fuel costs. Burners can also operate with excess air or fuel providing additional versatility in process applications.

(For Dual-Fuel Hi-Velocity Burners, see Bulletin 3640).

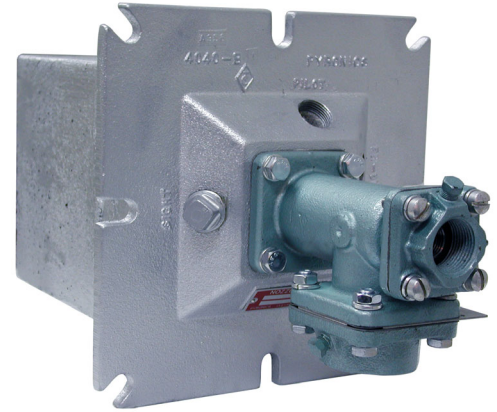

FEATURES

Hi-Velocity:	250 ft./sec.
Refractory Block:	3000°F (3300°F refractory available)
Block Casings:	Steel or alloy available for fiber lined furnaces.
Air/Gas Connections:	Flanged for ease of installation.
5 Sizes:	1 1/2" to 6" NPT Air Connections.
Ratings:	320,000 to 5,150,000 BTU/HR at 20 oz. air pressure at burner (see Table).
Turndown:	10 to 1
Excess Air:	300% (without pilot)
Excess Fuel:	40% (without pilot)
Burner Ports:	Pilot, flame monitoring, and sight (sight glass not included).
Direct Spark:	Available (low fire start only)
Preheated Air:	Up to 750°F as Std. (1000°F units available, consult factory).

APPLICATIONS

- Periodic Kilns - Shuttle Kilns - Tunnel Kilns
- Large Carbottom Furnaces - Heat Treating - Stress Relieving
- Ladle Heating - Impingement Heating - Reverberatory Furnaces

CAUTION: Operation of combustion equipment can be hazardous resulting in bodily injury or equipment damage. Each burner should be supervised by a combustion safeguard and only qualified personnel should install, make system adjustments and perform any required service.



ORDAN THERMAL PRODUCTS LTD.

Combustion Equipment & Controls for Industry
21 Amber St # 9, Markham Ontario Canada L3R 4Z3
Tel: (905) 475-9292 Fax: (905) 475-3286
www.ordanthermal.com

NOTICE: Pyronics practices a policy of continuous improvement in the design of its products. It reserves the right to change the specifications at any time without prior notice.

BURNERS HI-VELOCITY SINGLE TUNNEL

BULLETIN 3505
PAGE NO. 2

DIMENSIONS

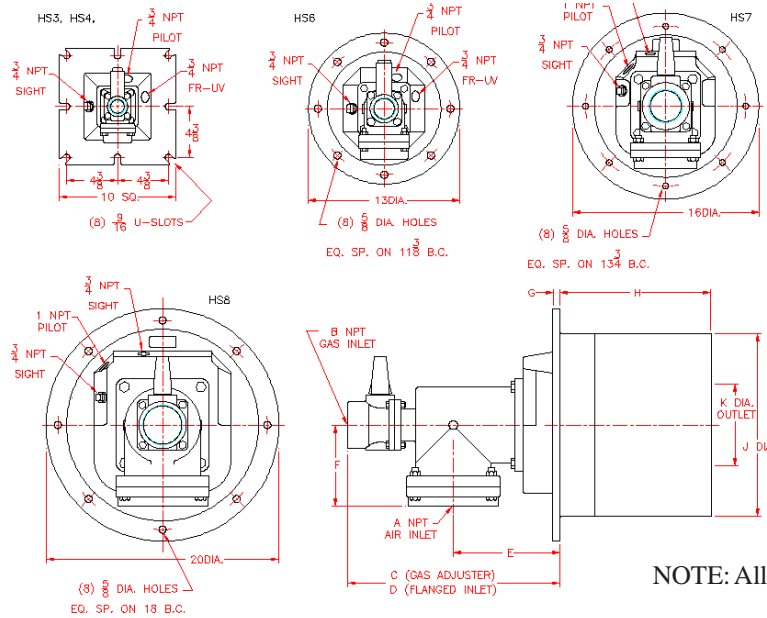

Model No.	A	B	C	D	E	F	G	H	J	K	L	Weight	
												Lbs.	Kgs.
HS 3-*-R	1-1/2	1	-	-	8-1/4	7-1/4	9	3/8	3-1/8	4-3/4	7	55	25.00
HS 4-*-R	2	1	-	-	9-1/4	8-1/4	9	3/8	3-3/8	5-1/8	7	52	23.60
HS 6-*-R	3	1-1/2	11-3/8	13	11-1/4	10-1/4	10	1/2	4-1/4	6	8	70	31.75
HS 7-*-R	4	2-1/2	13-3/4	16	16-1/2	14	12	1/2	5-3/8	8-1/2	11-3/4	180	81.63
HS 8-*-R	6	3	18	20	18-5/8	15-1/2	13	1/2	6-7/8	9	15-3/4	220	99.80

* Insert Letter: (GA) - Gas Adjuster (F) - Flanged Inlet

CAPACITY TABLE

Model No.	Natural Gas 0.64 Sp. Gr. 1000 BTU/HR @ 20 oz.	Flame Length on Ratio	Recommended Pilot	Recommended Direct Spark Electrode
HS 3	320	14"	P62 PBST	DSE - 3
HS 4	655	22"	P62 PBST	DSE - 3
HS 6	1,290	28"	P64 PBST	DSE - 1
HS 7	2,425	40"	P86 PBST	DSE - 1
HS 8	5,150	45"	P86 PBST	DSE - 11

ORDERING INFORMATION

Add to Model No. for Block Holder and Refractory required.

- 1 With Std. Refractory less Jacket 3000°F.
- 2 With Hi-Temp. Refractory Less Jacket 3300°F.
- C With Alloy Jacket & Std. Refractory 3000°F.
- D With Alloy Jacket & Hi-Temp. Refractory 3300°F.
- E With Short Alloy Jacket & Std. Refractory 3000°F.
- F With Short Alloy Jacket & Hi-Temp. Refractory 3300°F.

2. Specify Model No. & Quantity.
3. Type of Fuel and Pressure available.
4. Specify Pilot Model No. (If required).
5. Specify Sight Glass Model No. (If required).
6. Shipping Instructions.