

INDIRECT GAS-FIRED RECUPERATIVE COMBUSTION SYSTEMS

UHF RADIANT TUBE BURNERS

MODEL: UHF

Revision: 0

BULLETIN
3901

DESCRIPTION

UHF series burners are compact, sealed nozzle-mix units designed to operate in radiant tubes with maximum combustion efficiency over varying operating conditions.

UHF burners provide delayed mixing and uniform progressive combustion for even tube heating, temperature uniformity and optimum tube life. Flame length and geometry are adjustable through the possible use of an air-gas partial pre-mixing that suits the flame to the job.

UHF burners can be used with preheated air up to 480°C, and may be operated in a high-low, a high-low-off mode or fully modulated over a 5 to 1 turndown range, using excess air at low fire.

Burner ignition is achieved by a direct spark ignition electrode (“Wand”); flames can be monitored using UV scanners.

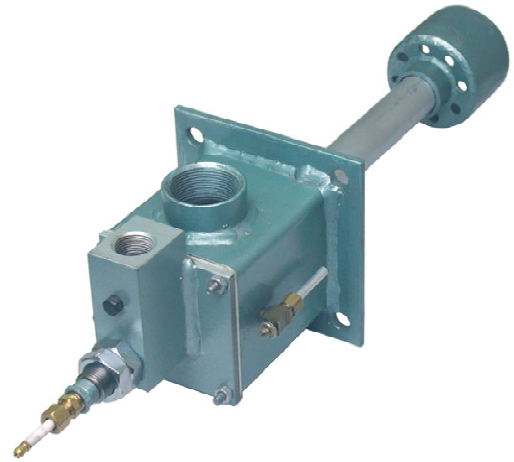

FEATURES

- Sealed nozzle mix design
- Superior flame stability and mixing at all firing rates
- Flame length adjustment
- 5 to 1 turndown with excess air at low fire
- Typical oxygen levels in the exhaust gases:
3 to 4% @ high fire
12 to 16% @ low fire
- Accepts hot air up to 480°C
- Low air and gas pressures
- Direct spark ignition “Wand”
- Excellent adaptability

APPLICATIONS

- Radiant “U” tubes
- Radiant “O” tubes
- Radiant “W” tubes
- Radiant “L” tubes
- Trident radiant tubes

CAPACITY TABLE

BURNER MODEL	MAXIMUM INPUT, BTU/HR	MINIMUM INPUT, BTU/HR	MAXIMUM AIR PRESSURE, OSI	MAXIMUM GAS PRESSURE, OSI	MINIMUM TO MAXIMUM TUBE SIZE, INCHES		PERCENT PRIMARY AIR MINIMUM TO MAXIMUM	
UHF-4	350,000	25,000	5.7	2.8	4	8	5	35
UHF-5	750,000	35,000	8	6	5	10	5	35

CAUTION: Operation of combustion equipment can be hazardous resulting in bodily injury or equipment damage. Each burner should be supervised by a combustion safeguard and only qualified personnel should install, make system adjustments and perform any required service.



ORDAN THERMAL PRODUCTS LTD
Combustion Equipment & Controls for Industry
21 Amber St # 9, Markham Ontario Canada L3R 4Z3
Tel: (905) 475-9292 Fax: (905) 475-3286
www.ordanthermal.com

NOTICE: Pyronics practices a policy of continuous improvement in the design of its products. It reserves the right to change the specifications at any time without prior notice.

PLUG-IN RECUPERATOR SYSTEM

The Plug-in recuperator system has everything needed for energy-efficient combustion: recuperator, burner, and all the necessary auxiliary components, from adjustable gas cocks to orifice meters (Fig. 1). Each package is custom designed and engineered to provide optimal performance.

The recuperator itself delivers higher preheat because it is placed inside the radiant tube, with direct access to hot exhaust gases. Unlike "stack" recuperators, it eliminates the possibility of heat loss via external connection.

If you're operating heat treat furnaces equipped with conventional U, O, W or Trident type radiant tubes, you're losing a great deal of energy through the exhaust stack.

A patented plug-in recuperator system from Pyronics can help you make far more efficient use of the fuel your furnace consumes. By using hot exhaust heat to preheat incoming combustion air, the furnace's fuel consumption is reduced dramatically (Fig. 2). The result is an average fuel savings of 30 to 45%.

Down to the last detail, these systems are designed and built to slash your operating costs.

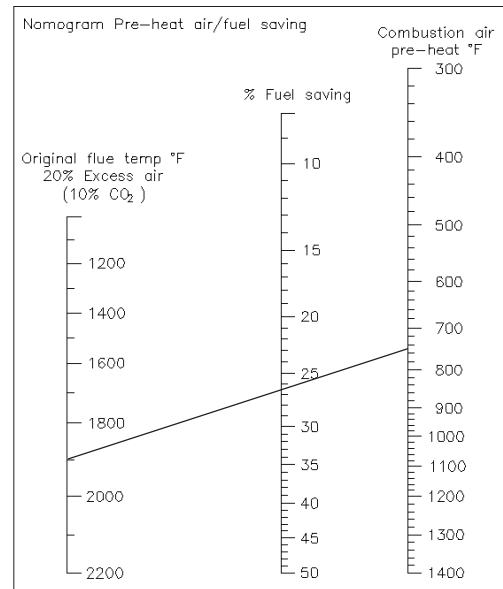

Fig. 3. To determine the fuel savings you can expect, draw a straight line from flue gas temperature to post-conversion preheat temperature. For example, air preheated to 750 degrees F from 1900 degrees F flue gas will result in fuel savings of about 26.5%.

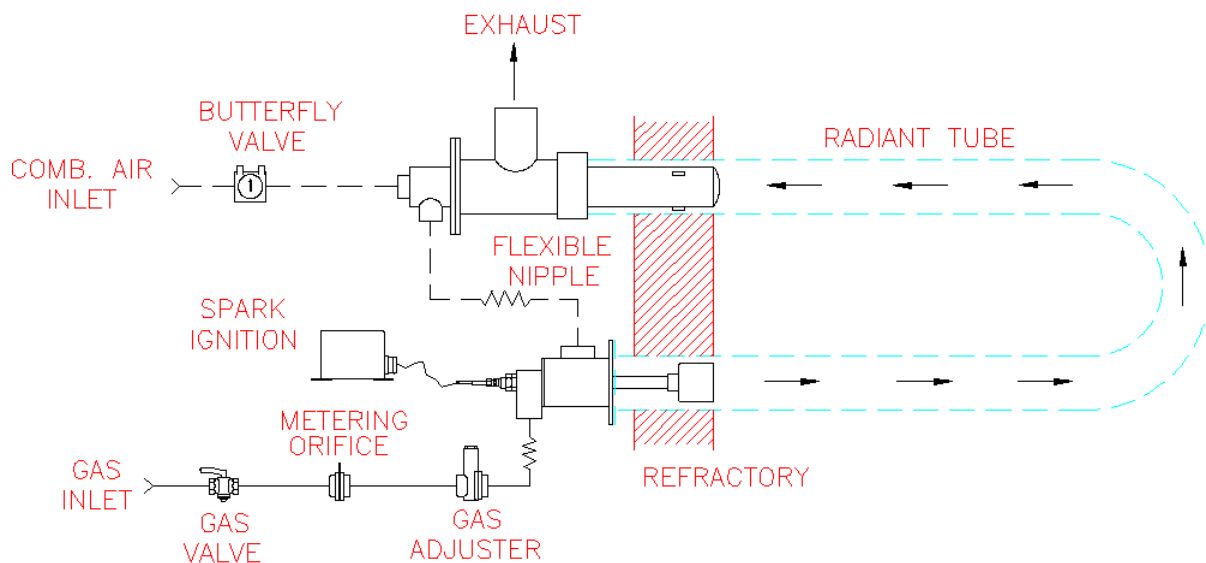

Fig. 1. Installed internally in a radiant tube, Pyronics plug-in recuperator system uses a combination of convective and radiant heat transfer to preheat incoming combustion air. The result: higher preheat and greater combustion efficiency.

PLUG-IN RECUPERATOR SYSTEM

UHF PLUG BURNER DIMENSIONS

“J”, “K”, & “M” are standard, but other types of mounting flanges can be supplied on request. It is also possible to use special adaptor flanges to suit the UHF burners to existing radiant tube configurations. Those adaptor flanges are necessary on the bigger diameter tubes (see application forms).

Dimension “L” is adaptable to varying wall thicknesses and mounting arrangements.

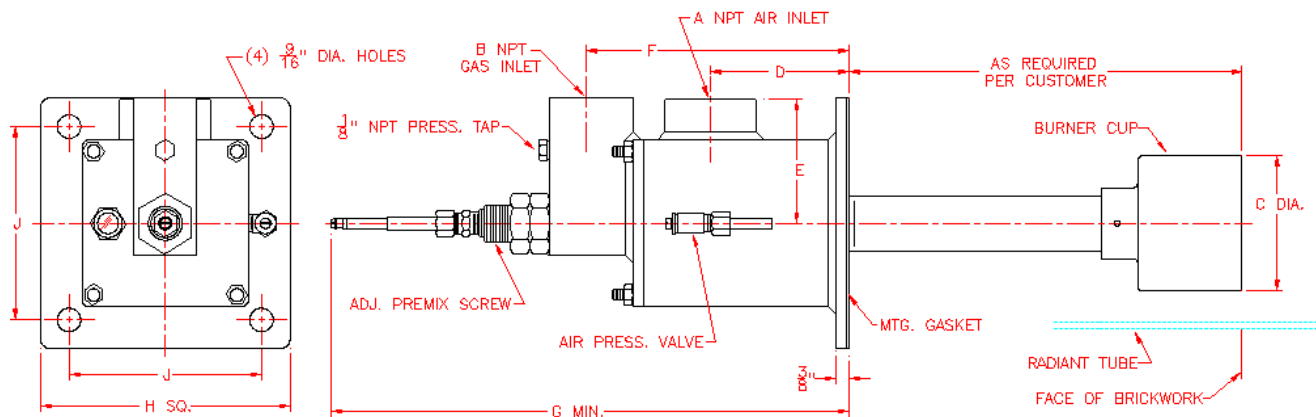

NOTE : OPTIONAL MTG. BRACKET AND SEAL TO MATCH CUST. INSTALLATION
AVAILABLE PER REQUEST
GAS INLET MAY BE ROTATED 90° OR 180° FROM AIR INLET IF NEEDED

Model No.	A NPT	B NPT	C DIA	D	E (NOM)	F	G MIN	H SQ	J SQ
UHF-4	1-1/2	3/4	3-1/4	3-3/8	3	6-3/8	12	6	4-5/8
UHF-5	2	1	4-1/4	3-7/8	3-1/2	7-7/8	14	8	6-1/2

All dimensions are in inches ± 1/8"

CAUTION: Operation of combustion equipment can be hazardous resulting in bodily injury or equipment damage. Each burner should be supervised by a combustion safeguard and only qualified personnel should install, make system adjustments and perform any required service.



ORDAN THERMAL PRODUCTS LTD
Combustion Equipment & Controls for Industry
21 Amber St # 9, Markham Ontario Canada L3R 4Z3
Tel: (905) 475-9292 Fax: (905) 475-3286
www.ordanthermal.com

NOTICE: Pyronics practices a policy of continuous improvement in the design of its products. It reserves the right to change the specifications at any time without prior notice.

PLUG-IN RECUPERATOR SYSTEM

PLUG RECUPERATOR DIMENSIONS

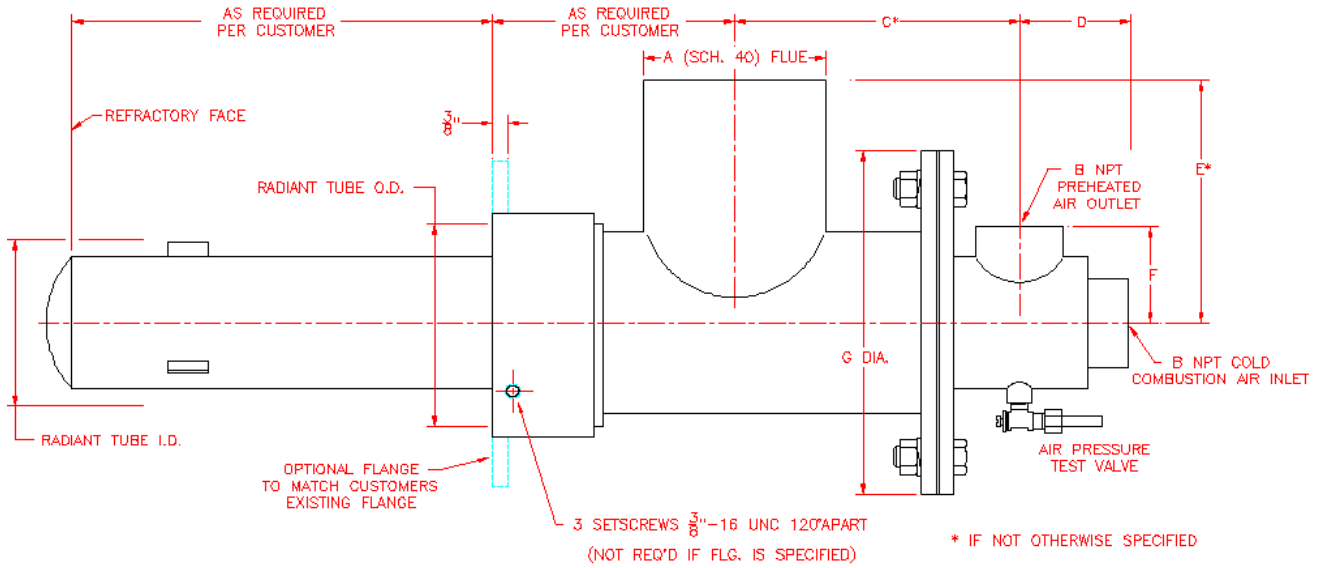

Model No.	A (SCH 40)	B NPT	C	D (NOM)	E	F (NOM)	G DIA
3" Plug	3	1-1/2	7	2-3/4	6	2-3/8	7
4" Plug	4	1-1/2	7	2-3/4	6	2-3/8	8-1/2
5" Plug	5	1-1/2	7	2-3/4	6	2-7/8	8-1/2
6" Plug	6	1-1/2	7	2-3/4	6	3-1/2	9-3/4
8" Plug	8	2-1/2	8-1/2	3-3/4	8	4-3/4	10-1/2

All dimensions are in inches $\pm 1/8$ "

ORDERING INFORMATION

Contact factory for assistance.