

REGULATORS SPRING BIASED 300 °F SERVICE

MODEL: 5114-BZR-B-300
Revision: 0

BULLETIN
5114

DESCRIPTION

BZR-B-300 is designed with an adjustable compensation spring to bias the regulator providing a smooth transition to excess air operation at low fire. Using a gas adjuster downstream of a negative biased regulator, high fire can be set to stoichiometric conditions. As the system is turned down, the spring bias will subtract from the combustion air pressure causing the burner to go lean. Adjusting the screw under the cap assembly permits biasing the fuel/air ratio from high fire to low fire at a fixed, controlled rate.

As shipped, the regulator is set at zero bias.

For installation, see Bulletin 5101 Installation.



CAPACITY TABLE

Model Number	Pipe Size		SCFH Gas Flow @ 4.0" W.C. Pressure Drop			
	Inlet	Outlet	MFD. 0.4 Sp. Gr.	NAT. 0.6 Sp. Gr.	AIR 1.0 Sp. Gr.	L.P. 1.5 Sp. Gr.
6-BZR-B-300	3/4"	3/4"	790	650	500	410
8-BZR-B-300	1"	1"	1,580	1,290	1,000	820
12-BZR-B-300	1-1/2"	1-1/2"	3,160	2,580	2,000	1,640
16-BZR-B-300	2"	2"	5,530	4,520	3,500	2,860
20-BZR-B-300	2-1/2"	2-1/2"	7,900	6,450	5,000	4,100
24-BZR-B-300	3"	3"	12,600	10,300	8,000	6,500
32-BZR-B-300	4"	4"	22,100	18,100	14,000	11,400

FEATURES

- Accuracy:
 - Low - Flow: ± 0.1 " W.C.
 - Full - Flow: ± 0.3 " W.C.
- Turndown: up to 20:1
- Continuous operation to 300 °F
- For use with High Sulphur Gases
- All units factory tested and sealed before shipment
- Maximum inlet pressure: 2.0 psig
- Minimum pressure drop through regulator: 4.0" W.C.
- Sensitivity - Responds to signal pressure differential as low as 0.04" W.C.
- Adjustable spring bias from: + 0.3/-5.0" W.C.

CAUTION: Operation of combustion equipment can be hazardous resulting in bodily injury or equipment damage. Each burner should be supervised by a combustion safeguard and only qualified personnel should install, make system adjustments and perform any required service.



pyronics inc.

COMBUSTION FOR INDUSTRY

17700 MILES ROAD
CLEVELAND, OH 44128
www.pyronics.com

Tel: 216-662-8800
Fax: 216-663-8954
marketing@pyronics.com

NOTICE: PYRONICS practices a policy of continuous improvement in the design of its products. It reserves the right to change the specifications at any time without prior notice.

REGULATORS SPRING BIASED 300 °F SERVICE

BULLETIN 5114
PAGE NO.2

DIMENSIONS: 3/4" - 3" SIZES

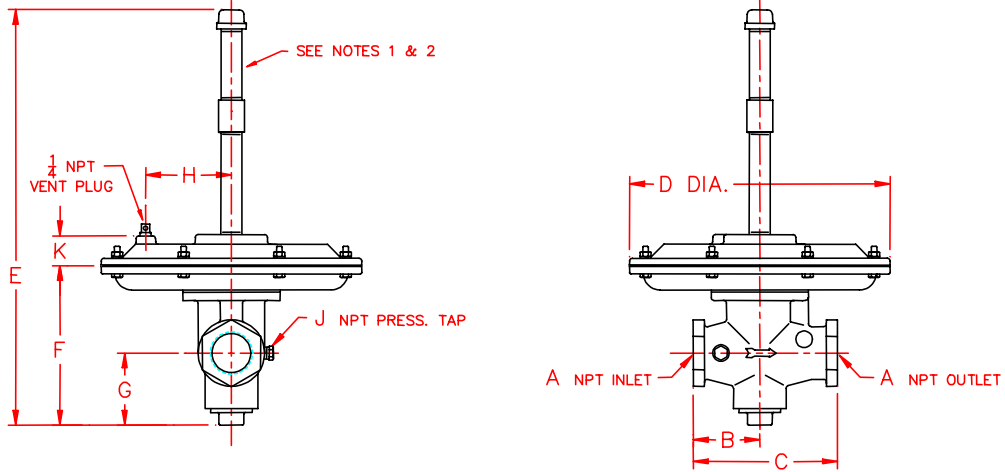

Model Number	A	B	C	D	E	F	G	H	K	Weight	
										Lbs.	Kgs.
6-BZR-B-300	3/4	2-1/2	5	8-1/4	20-3/4	4-7/8	2	-----	-----	7.0	3.17
8-BZR-B-300	1	2-3/8	4-3/4	9-3/4	24	4-3/4	2	3-3/8	1-1/4	9.0	4.07
12-BZR-B-300	1-1/2	3	6-1/2	11-3/4	26-1/2	7-1/4	3-1/4	3-7/8	1-3/8	16.0	7.25
16-BZR-B-300	2	3-1/2	7-1/2	11-3/4	30-7/8	8-1/8	3-7/8	3-7/8	1-3/8	21.0	9.52
20-BZR-B-300	2-1/2	4	8-3/4	14	31-1/8	8-3/4	3-5/8	3-5/8	1-7/8	51.0	23.13
24-BZR-B-300	3	5-3/4	11-1/2	14	35-3/8	10-5/8	4-5/8	3-5/8	1-7/8	61.0	27.66

DIMENSIONS: 4" SIZE

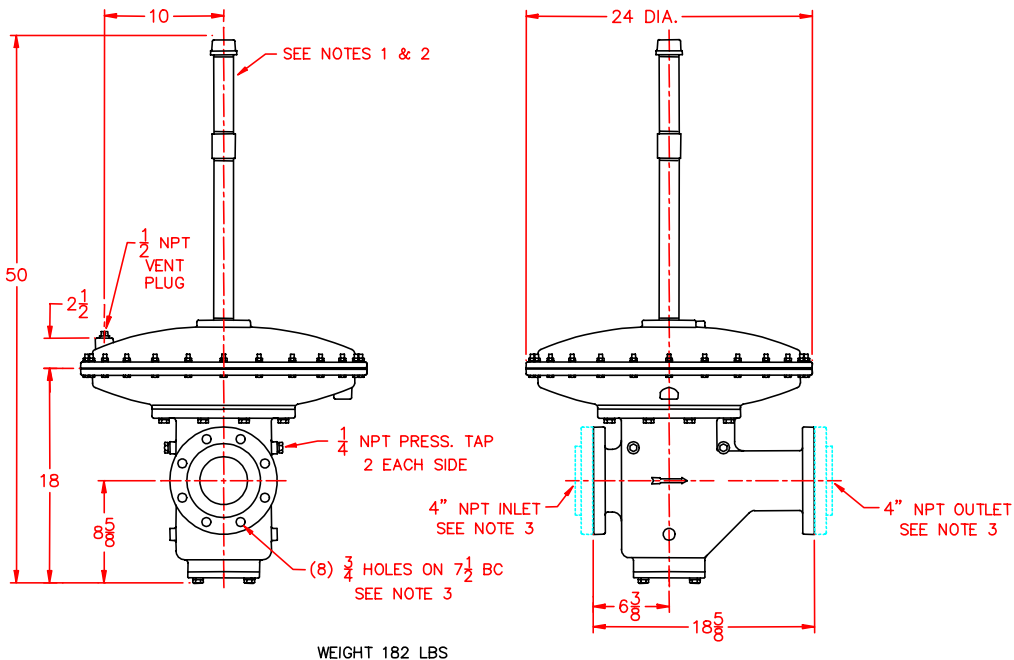

NOTES:

1. Spring housing must be perpendicular to pipe run in an upright position.
2. Gas pipe run must be horizontal and level.
3. Designed to accept standard 4" ANSI flanges.
4. All dimensions are in inches.

ORDERING INFORMATION

1. Specify Inlet and Outlet Pressure.
2. Type of Gas, Flow, Specific Gravity and Temperature.
3. Specify Model Number and Quantity.
4. Shipping Instructions.

REGULATORS SPRING BIASED 300 °F SERVICE

BULLETIN 5114
PAGE NO.3

SETTING THE BZR-B-300 BIAS AIR RATE AT LOW FIRE

1. With the furnace firing and hot, cycle the combustion system to low fire following the steps in the manufacturer's operating instructions. Carefully monitor the burners to insure they do not extinguish. Remove the cap assembly (item 1).
2. If possible, take an oxygen reading of the flue gas. If more oxygen is needed, turn the locknuts (item 2) clockwise to increase spring tension and decrease gas flow. After each adjustment on the locknuts the cap assembly (item 1) must be replaced to prevent leakage of the air impulse pressure.
3. Return to high fire and reset the adjustable orifice valve for the proper gas flow at this firing rate.
4. Return to low fire and repeat the procedure in steps 1, 2, and 3 as many times as is necessary to achieve the oxygen level desired.
5. Once the oxygen level is reached, tighten the locknuts (item 2) to each other and install the cap assembly (item 1) with a pipe wrench. **DO NOT** overtighten.

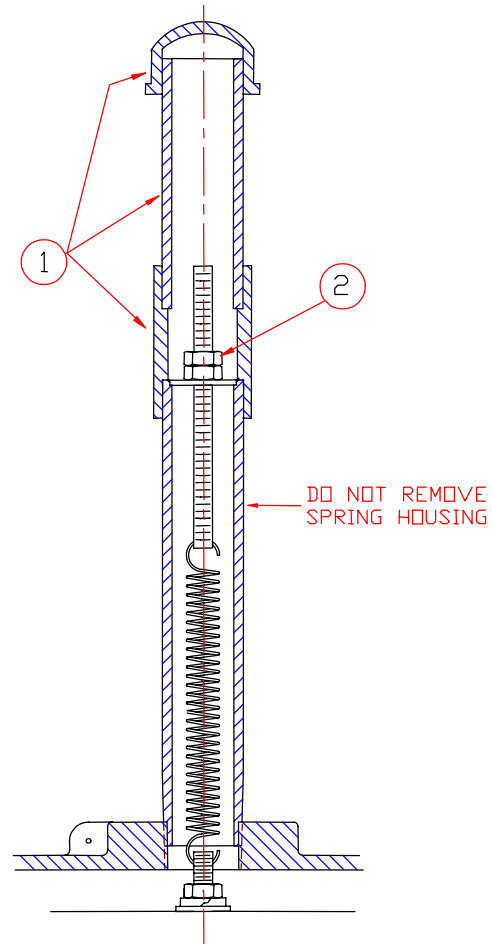

CAUTION: Operation of combustion equipment can be hazardous resulting in bodily injury or equipment damage. Each burner should be supervised by a combustion safeguard and only qualified personnel should install, make system adjustments and perform any required service.



pyronics inc.

COMBUSTION FOR INDUSTRY
17700 MILES ROAD
CLEVELAND, OH 44128
www.pyronics.com

Tel: 216-662-8800
Fax: 216-663-8954
marketing@pyronics.com

NOTICE: PYRONICS practices a policy of continuous improvement in the design of its products. It reserves the right to change the specifications at any time without prior notice.