

REGULATORS BALANCED RATIO 300 °F SERVICE

MODEL: 5116-BRR-300

Revision: 0

**BULLETIN
5116**

DESCRIPTION

BRR-300 -- Balanced Ratio Regulators are designed to provide accurate air/fuel ratio control of cross-connected combustion systems. The delivery pressure of the BRR-300 will match that of the cross-connected signal being applied to the upper diaphragm chamber, as long as the minimum differential is maintained. A turndown ratio of 20 to 1 is possible with the BRR-300.

The Balanced Ratio Series features large main diaphragms, a balancing diaphragm and soft rubber seat to insure good control at low turndown ratios.

For installation, see Bulletin 5101 Installation.

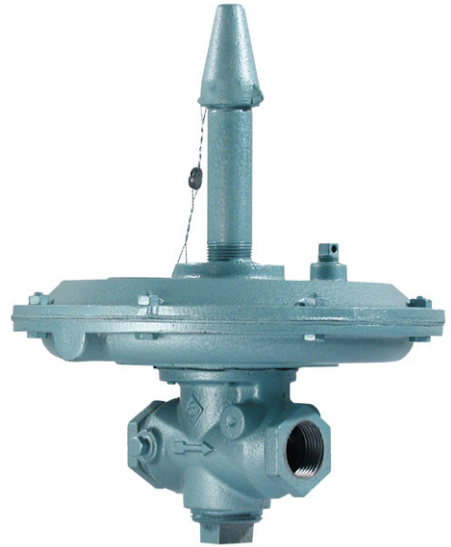

CAPACITY TABLE

Model Number	Pipe Size		SCFH Gas Flow @ 4.0" W.C. Pressure Drop			
	Inlet	Outlet	MFD.	NAT.	AIR	L.P.
			0.4 Sp. Gr.	0.6 Sp. Gr.	1.0 Sp. Gr.	1.5 Sp. Gr.
6 - BRR - 300	3/4"	3/4"	790	650	500	410
8 - BRR - 300	1"	1"	1,580	1,290	1,000	820
12 - BRR - 300	1-1/2"	1-1/2"	3,160	2,580	2,000	1,640
16 - BRR - 300	2"	2"	5,530	4,520	3,500	2,860
20 - BRR - 300	2-1/2"	2-1/2"	7,900	6,450	5,000	4,100
24 - BRR - 300	3"	3"	12,600	10,300	8,000	6,500
32 - BRR - 300	4"	4"	22,100	18,100	14,000	11,400

FEATURES

- Accuracy:
 - Low - Flow: ± 0.1 " W.C.
 - Full - Flow: ± 0.3 " W.C.
- Turndown: up to 20:1
- Operating temperatures to 300 °F
- All units factory tested and sealed before shipment
- Maximum inlet pressure: 5.0 psig
- Maximum pressure differential: 4.0 psig
- Minimum pressure differential: 10" W.C.

CAUTION: Operation of combustion equipment can be hazardous resulting in bodily injury or equipment damage. Each burner should be supervised by a combustion safeguard and only qualified personnel should install, make system adjustments and perform any required service.



ORDAN THERMAL PRODUCTS LTD
 Combustion Equipment & Controls for Industry
 21 Amber St # 9, Markham Ontario Canada L3R 4Z3
 Tel: (905) 475-9292 Fax: (905) 475-3286
www.ordanthermal.com

NOTICE: PYRONICS practices a policy of continuous improvement in the design of its products. It reserves the right to change the specifications at any time without prior notice.

REGULATORS BALANCED RATIO 300 °F SERVICE

BULLETIN 5116
PAGE NO.2

DIMENSIONS: 3/4" - 3" SIZES

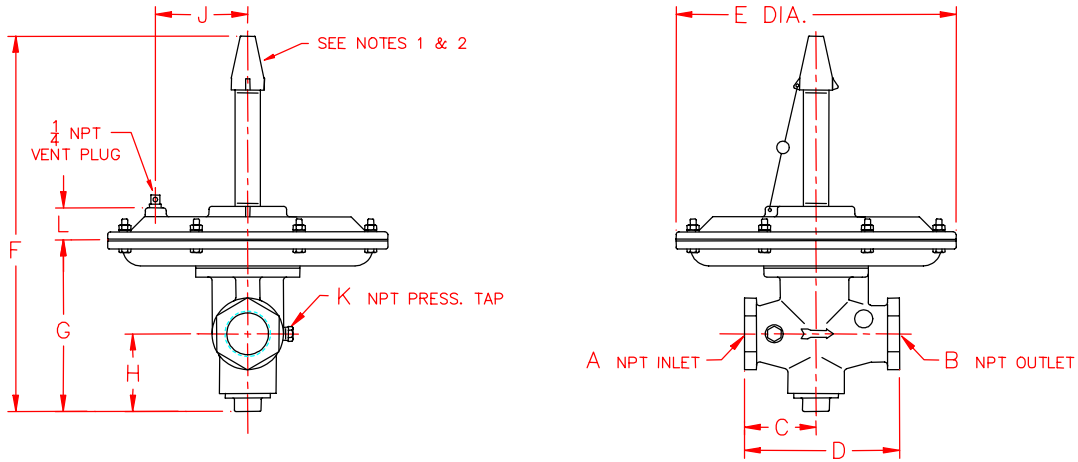

Model Number	A	B	C	D	E	F	G	H	J	K	L	Weight Lbs.
6 - BRR - 300	3/4	3/4	2-1/2	5	8-1/4	11-1/4	4-7/8	2	2-3/4	1/8	1-1/4	6.5
8 - BRR - 300	1	1	2-3/8	4-3/4	9-3/4	11-3/4	4-3/4	2	3-3/8	1/8	1-1/4	8.5
12 - BRR - 300	1-1/2	1-1/2	3	6-1/2	11-3/4	15-3/4	7-1/4	3-1/4	3-7/8	1/4	1-3/8	15.5
16 - BRR - 300	2	2	3-1/2	7-1/2	11-3/4	16-1/8	8-1/8	3-7/8	3-7/8	1/4	1-3/8	20.0
20 - BRR - 300	2-1/2	2-1/2	4	8-3/4	14	17-5/8	8-3/4	3-5/8	3-5/8	1/4	1-7/8	50.0
24 - BRR - 300	3	3	5-3/4	11-1/2	14	20-3/8	10-5/8	4-5/8	3-5/8	1/4	1-7/8	60.5

DIMENSIONS: 4" SIZE

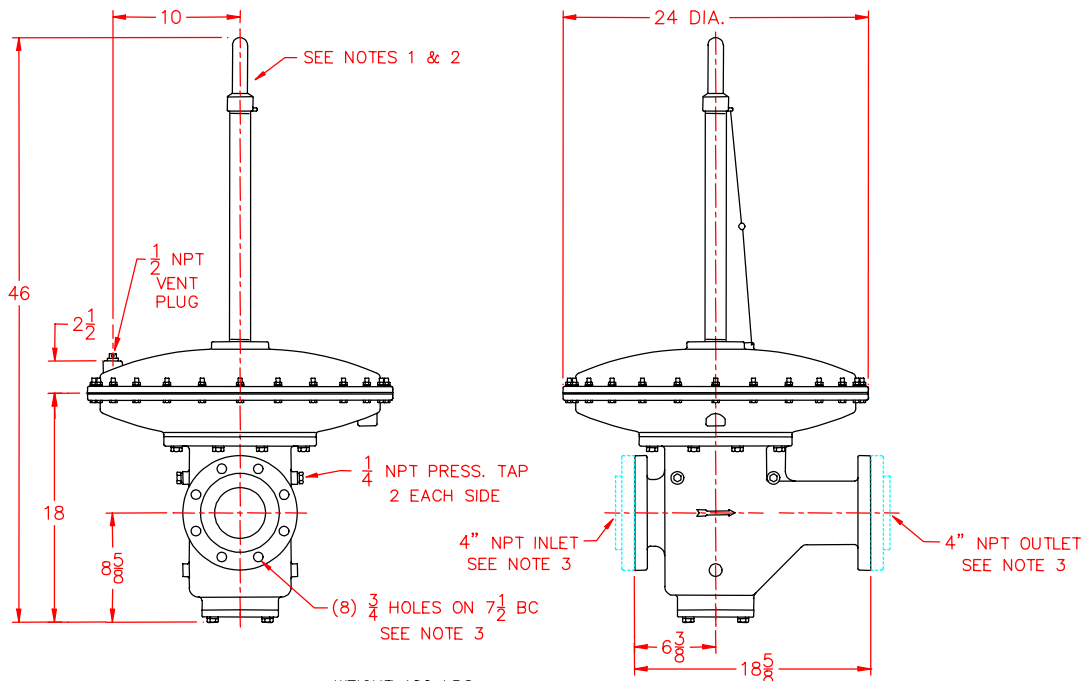

WEIGHT 180 LBS

NOTES:

1. Spring housing must be perpendicular to pipe run in an upright position.
2. Gas pipe run must be horizontal and level.
3. Designed to accept standard 4" ANSI flanges.
4. All dimensions are in inches.

ORDERING INFORMATION

1. Specify Inlet and Outlet Pressure.
2. Type of Gas, Flow, Specific Gravity and Temperature.
3. Specify Model Number and Quantity.
4. Shipping Instructions.