

# REGULATORS BALANCED ZERO 500 °F SERVICE

**MODEL: 5112 - BZR - 500**

Revision: 0

**BULLETIN  
5112**

## DESCRIPTION

**BZR-500 Series Balanced Zero Regulators** are used for precise control of heated gases or for equipment locations subjected to high ambient temperatures. They are designed for continuous operation up to 500 °F and to resist corrosion from high sulphur or other corrosive gases. The special high temperature construction does not sacrifice performance.

The BZR-500 series regulators duplicate the precise control characteristics of the standard BZR Regulators. They automatically adjust valve position to hold a desired precise outlet pressure. Slight variations in inlet pressure do not affect the performance.

For installation, see Bulletin 5101 Installation.



## CAPACITY TABLE

Model Number	Pipe Size		SCFH Gas Flow @ 4.0" W.C. Pressure Drop			
	Inlet	Outlet	MFD. 0.4 Sp. Gr.	NAT. 0.6 Sp. Gr.	AIR 1.0 Sp. Gr.	L.P. 1.5 Sp. Gr.
8 - BZR - 500	1"	1"	1,580	1,290	1,000	820
12 - BZR - 500	1-1/2"	1-1/2"	3,160	2,580	2,000	1,640
20 - BZR - 500	2-1/2"	2-1/2"	7,900	6,450	5,000	4,100
24 - BZR - 500	3"	3"	12,600	10,300	8,000	6,500
32 - BZR - 500	4"	4"	22,100	18,100	14,000	11,400

## FEATURES

- Accuracy:
  - Low - Flow  $\pm 0.1"$  W.C.
  - Full - Flow  $\pm 0.3"$  W.C.
- Turndown up to 200:1
- Continuous operation to 500 °F
- For use with High Sulphur Gases
- All units factory tested and sealed before shipment
- Maximum inlet pressure: 5.0 psig
- Maximum pressure differential: 14.0" W.C.
- Sensitivity - Responds to signal pressure differential as low as 0.04" W.C.

**CAUTION:** Operation of combustion equipment can be hazardous resulting in bodily injury or equipment damage. Each burner should be supervised by a combustion safeguard and only qualified personnel should install, make system adjustments and perform any required service.



**ORDAN THERMAL PRODUCTS LTD**  
 Combustion Equipment & Controls for Industry  
 21 Amber St # 9, Markham Ontario Canada L3R 4Z3  
 Tel: (905) 475-9292 Fax: (905) 475-3286  
[www.ordanthermal.com](http://www.ordanthermal.com)

**NOTICE:** PYRONICS practices a policy of continuous improvement in the design of its products. It reserves the right to change the specifications at any time without prior notice.

# REGULATORS BALANCED ZERO 500 °F SERVICE

BULLETIN 5112  
PAGE NO.2

## DIMENSIONS: 3/4" - 3" SIZES

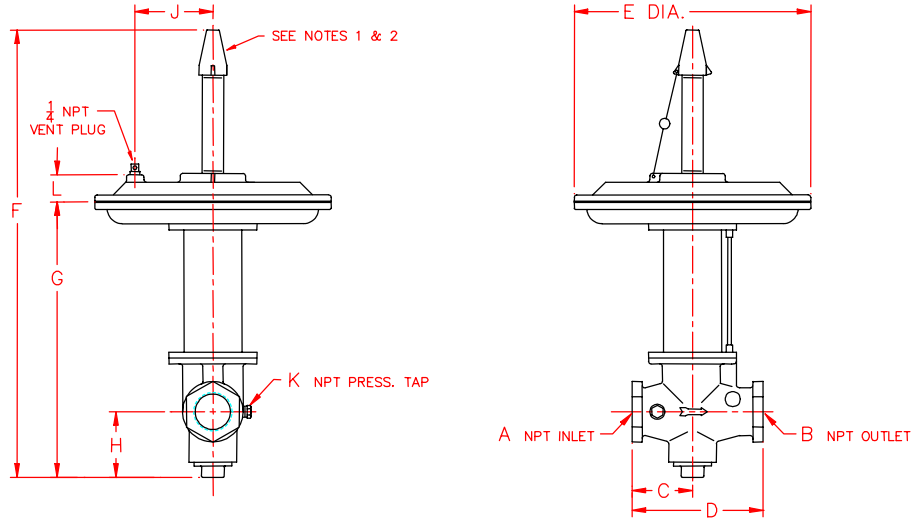

Model Number	A	B	C	D	E	F	G	H	J	K	L	Weight Lbs.
8 - BZR - 500	1	1	2-3/8	4-3/4	9-3/4	22-7/8	15-7/8	2	3-3/8	1/8	1-1/4	12.0
12 - BZR - 500	1-1/2	1-1/2	3	6-1/2	11-3/4	33-1/4	18-3/8	3-1/4	3-7/8	1/4	1-3/8	25.5
20 - BZR - 500	2-1/2	2-1/2	4	8-3/4	14	36-1/2	21-1/4	3-5/8	3-5/8	1/4	1-7/8	66.5
24 - BZR - 500	3	3	5-3/4	11-1/2	14	38-3/8	23	4-5/8	3-5/8	1/4	1-7/8	77.5

## DIMENSIONS: 4" SIZE

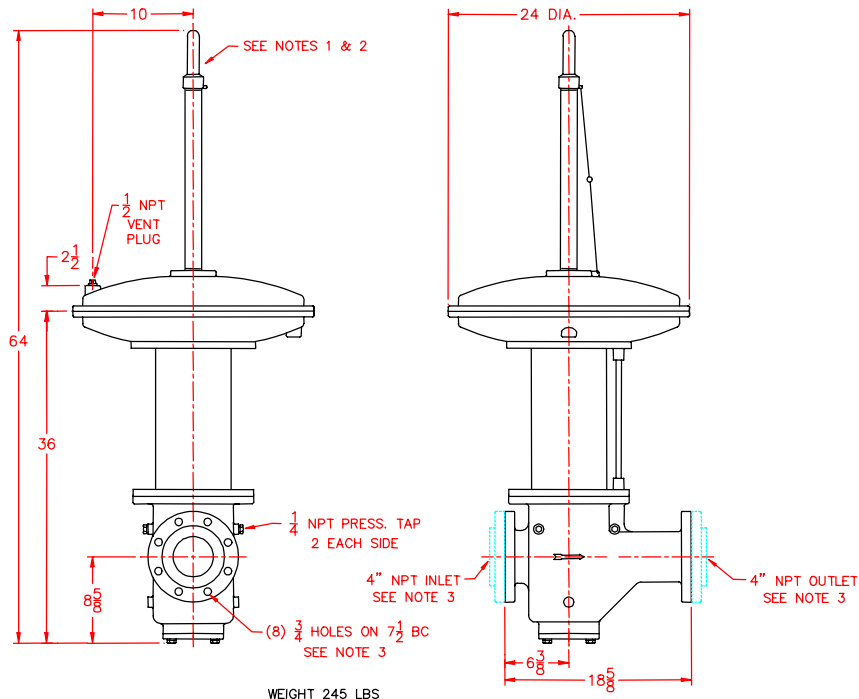

**NOTES:**

1. Spring housing must be perpendicular to pipe run in an upright position.
2. Gas pipe run must be horizontal and level.
3. Designed to accept standard 4" ANSI flanges.
4. All dimensions are in inches.

## ORDERING INFORMATION

1. Specify Inlet and Outlet Pressure.
2. Type of Gas, Flow, Specific Gravity and Temperature.
3. Specify Model Number and Quantity.
4. Shipping Instructions.