

# REGULATOR REPAIR KIT

MODEL: 5131

Revision: 0

BULLETIN  
5131

## FIELD REPAIR INSTRUCTIONS FOR 5101-BZR REGULATOR

PYRONICS, INC. DOES NOT RECOMMEND FIELD REPAIRS OF 5101-BZR REGULATORS. IT IS EXTREMELY DIFFICULT TO GET THE SAME SETTING IN THE FIELD AS OPPOSED TO A FACTORY BUILT OR REBUILT UNIT. IN ADDITION, THERE IS A POSSIBILITY OF THE REGULATOR BEING ASSEMBLED IN AN IMPROPER MANNER WHICH COULD CREATE A HAZARDOUS CONDITION.

We realize, that on occasion, a situation develops that a field repair is the most practical solution.

The following instructions pertain to 3/4" through 3" size of 5101-BZR Regulators manufactured by Pyronics. The minimum repairs will be considered initially, and then complete rebuild will be discussed. **In the majority of cases the repair of a BZR Regulator will require replacement of the main diaphragm. In this case, a partial disassembly is required.**

1. Remove the bottom plug [item 13] from the regulator body [item 12] and inspect, as well as possible, the valve disc [item 25], o-ring [item 31] and valve seat for dirt or damage. After inspection, push the valve firmly into the seat and block in this position. A piece of Styrofoam or similar material can be used to hold the valve disc in place.

**NOTE:** If it is suspected that the valve disc or valve seat is damaged, a complete disassembly of the unit is necessary. Go to step 17.

2. Snip the seal wire and remove cap [item 1]. Pull up gently on the spring adjusting screw [item 14] and unhook spring [item 17]. Drop spring into spring housing [item 2]. **CAUTION:** Do not overstretch spring; stretch just enough to remove from adjusting screw.
3. Remove the spring housing [item 2] and spring [item 17].
4. Remove the top cover [item 3] to expose the diaphragm assembly. Inspect the top diaphragm pan [item 23]. It should be perfectly smooth and flat. Remove the top nut [item 15] of the top diaphragm assembly. **CAUTION:** Hold the bottom nut [item 15] securely since it is important that the bottom nut is not moved.
5. Remove the top pan and inspect the main diaphragm. Then inspect the bottom diaphragm pan.
6. Inspect the seal diaphragm for damage, however, do not remove the seal diaphragm unless it is absolutely necessary. At this point, no further disassembly is required if you find that only the main diaphragm and/or pans have been damaged. Replace damaged parts. If seal diaphragm is damaged, go to step 17.
7. See Section "B". Assemble lower diaphragm pan [item 23], with flange down, on valve stem [item 18], then main diaphragm [item 7], fiber washer [item 22], top pan [item 23], with flange up, steel washer [item 21], lock washer [item 20], then upper nut [item 15].

**CAUTION:** Align holes in diaphragm with holes in the bottom cover [item 8]. Diaphragm must be flat and free from wrinkles. Hold bottom nut [item 15] stationary and tighten top nut [item 15].

8. It is extremely important that there is no twist in the seal diaphragm. To check for this twist, hold top pan [item 23] and rotate main diaphragm assembly to the left until it becomes tight, mark position on bottom cover, then rotate to right and mark position on bottom cover. The hole in the diaphragm should align with the cover holes midpoint between these two positions. If the position of main diaphragm is not proper, loosen top nut [item 15], relocate main diaphragm and repeat procedure.
9. See Section "A". Assemble gaskets [item 6] below and above main diaphragm [item 7], then assemble bolts [item 5] up through cover and gaskets.
10. Hook one end of spring [item 17] through hole in valve stem [item 18].
11. Assemble top cover [item 3] over bottom cover putting spring through center of top cover. Assemble nuts [item 26] finger tight only.

**CAUTION:** Operation of combustion equipment can be hazardous resulting in bodily injury or equipment damage. Each burner should be supervised by a combustion safeguard and only qualified personnel should install, make system adjustments and perform any required service.



**ORDAN THERMAL PRODUCTS LTD**  
Combustion Equipment & Controls for Industry  
21 Amber St # 9, Markham Ontario Canada L3R 4Z3  
Tel: (905) 475-9292 Fax: (905) 475-3286  
[www.ordanthermal.com](http://www.ordanthermal.com)

**NOTICE:** PYRONICS practices a policy of continuous improvement in the design of its products. It reserves the right to change the specifications at any time without prior notice.

# REGULATOR REPAIR KIT

BULLETIN 5131  
PAGE NO. 2

12. Remove valve disc locking device. Move valve stem [item 18] back and forth to prevent tight spots in main diaphragm, then tighten nuts [item 26] and bolts [item 5] using “criss-crossing” tightening sequence.
13. Assemble spring housing [item 2] to top cover using pipe dope on threads. **CAUTION:** Machined recess in spring housing is in top position toward the cap [item 1].
14. With a hook wire tool pull spring [item 17] through spring housing and assemble to adjusting screw [item 14].  
**CAUTION:** Do not overstretch spring; stretch spring just enough to assemble to adjusting screw.
15. Replace plug [item 13] in bottom of valve body and cap [item 1] on spring housing using thread sealant.
16. If the regulator appears to be functioning normally, install a new seal wire.

**NOTE:** It may be necessary to make minor adjustments to the adjusting screw. See test instructions at end of assembly instructions.

**The following additional instructions are for situations where the seal diaphragm has been damaged and/or the valve assembly must be replaced:**

17. Disassemble the regulator completely and inspect the valve seat in the body [item 12], the o-ring [item 31] and the valve assembly [items 25 and 18]. The valve disc should be tightly screwed onto the valve stem with epoxy or gasket sealant. The parting line on the o-ring should run radially around disc.
18. Assemble valve disc assembly into valve body and lock into position with a piece of Styrofoam or similar material. By visual inspection be sure valve stem is concentric with top opening of valve body.
19. Put gasket sealant on valve stem, in area where seal nut [item 15] (see section “C”) will be assembled. (See table on page 3 for seal nut setting opposite regulator size.) Assemble bottom seal nut [item 15] in position, then put gasket sealant on top of seal nut and around the valve stem.
20. Assemble in following order (from bottom to top), steel washer [item 21], fiber washer [item 22], seal diaphragm [item 10] (align with impulse hole “X”), fiber washer [item 22], steel washer [item 21], lockwasher [item 20] and then top seal nut [item 15].
21. By holding washers with fingers, tighten top seal nut [item 15]. Check position of impulse hole in seal diaphragm with impulse hole in valve body. Realign, if necessary, by loosening valve disc holder and rotating valve stem. Relock valve disc.
22. Place a new seal gasket [item 9] under seal diaphragm and also on top, aligning holes with impulse hole in body.
23. Place bottom cover [item 8] on top of valve body, being sure that impulse hole “X” aligns with impulse hole in body. Assemble bolts [item 11] with lockwashers [item 29] using thread sealant. Do not tighten. **CAUTION:** By observing through bolt holes, be sure seal diaphragm is clear of holes.
24. Allow valve disc assembly to move away (down) from valve seat the amount specified as “seal bag” in table on page 3 opposite regulator size. This operation will set an adequate amount of slack in the seal diaphragm.
25. **CAUTION:** Be sure stem of valve disc assembly is centered. Then tighten bolts [item 11] holding bottom cover to valve body.
26. Put thread sealant on valve stem, in area where bottom main diaphragm nut [item 15] will be assembled. (See table on page 3 for main nut setting opposite regulator size.) Assemble main diaphragm nut [item 15] in position, then put thread sealant on top of nut and around valve stem.

**Now follow steps 7 through 16.**

## TEST INSTRUCTIONS

1. Adjust desired Air-Fuel Ratio on Burner.
2. Turn burner to low fire and adjust regulator spring tension for a differential between the top load and outlet pressure of + 0.0 to - 0.1” W.C. on low fire. (See Testing Diagram on page 3 for manometer hookup.)

# REGULATOR REPAIR KIT

BULLETIN 5131  
PAGE NO.3

## CROSS SECTION

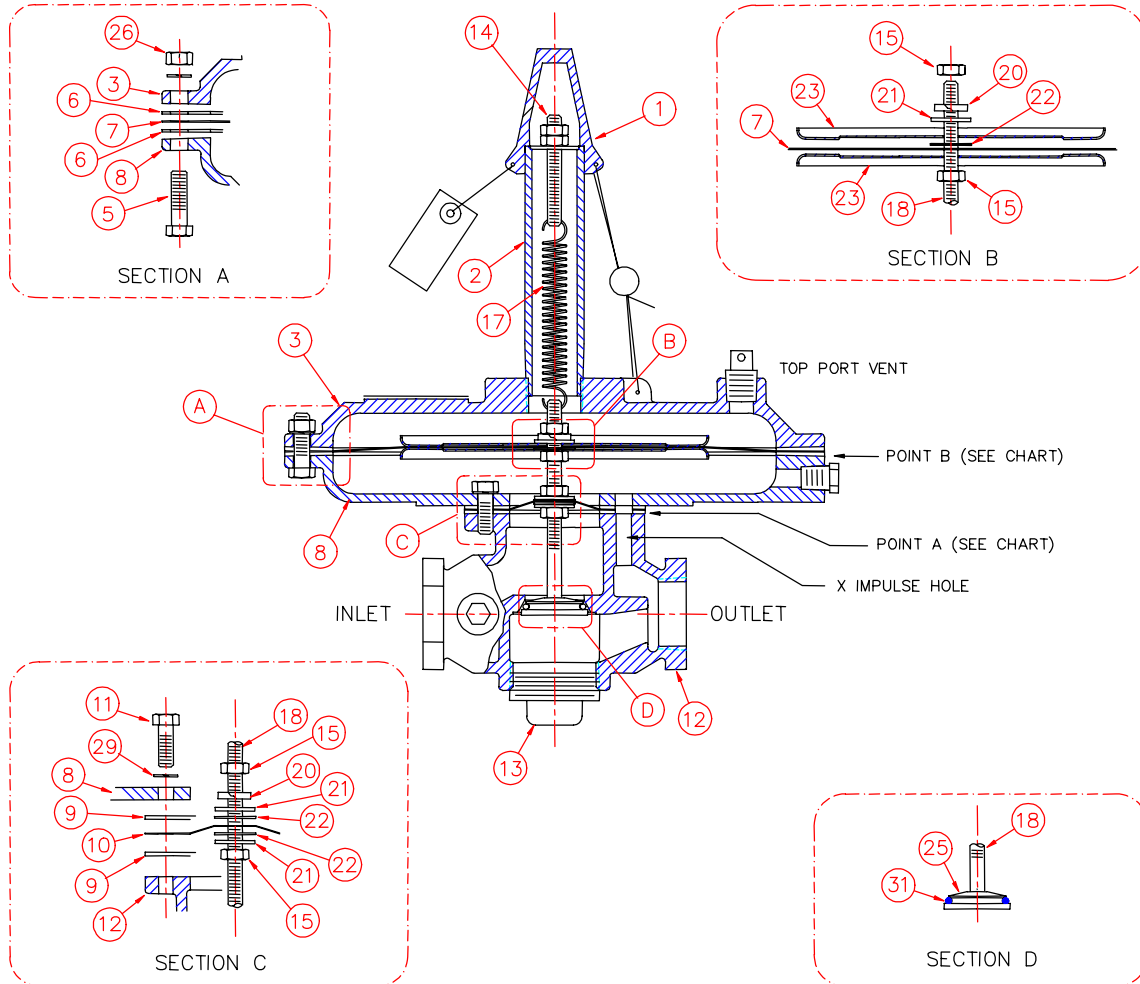

## REGULATOR SETTINGS

SETTINGS FROM LEVEL-BODY (POINT 'A') AND BOTTOM COVER (POINT 'B')					
REGULATOR MODEL NO.	REPAIR KIT MODEL NO.	PIPE SIZE	SEAL BAG	SEAL NUT *	MAIN NUT *
5101- 6 BZR	5131- 6 RK	3/4"	1/4"	+3/4 turns	Level
5101- 8 BZR	5131- 8 RK	1"	3/8"	-1 turn	+1 turn
5101-12 BZR	5131-12 RK	1-1/2"	5/8"	-3-1/2 turns	+1 turn
5101-16 BZR	5131-16 RK	2"	5/8"	+3 turns	+3 turns
5101-20 BZR	5131-20 RK	2-1/2"	5/8"	+1 turn	+2 turns
5101-24 BZR	5131-24 RK	3"	1"	-2-1/3 turns	+2-1/2 turns

\* + turn up  
- turn down

## TESTING DIAGRAM

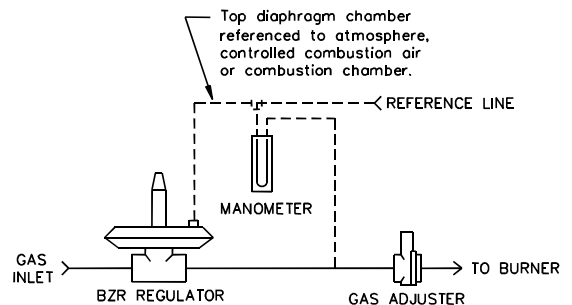

**CAUTION:** Operation of combustion equipment can be hazardous resulting in bodily injury or equipment damage. Each burner should be supervised by a combustion safeguard and only qualified personnel should install, make system adjustments and perform any required service.



**ORDAN THERMAL PRODUCTS LTD**  
Combustion Equipment & Controls for Industry  
21 Amber St # 9, Markham Ontario Canada L3R 4Z3  
Tel: (905) 475-9292 Fax: (905) 475-3286  
www.ordanthermal.com

**NOTICE:** PYRONICS practices a policy of continuous improvement in the design of its products. It reserves the right to change the specifications at any time without prior notice.