

REGULATORS PILOT CONTROL GAS / OIL

MODEL: 5107 - PCR

Revision: 0

BULLETIN
5107

DESCRIPTION

PCR - Pilot Control Regulators are the oil or dual-fuel versions of the FCR regulators (Bulletin 5105) and offer maximum control and fuel efficiency on oil or dual-fuel applications involving preheated air to the burners, or where burners fire against a varying back pressure.

The primary application of the 6 PCR is to impulse an OAR — Oil-Air Ratio Regulator (Bulletin 5301). The pressure to the OAR will be 2.5 times the pressure differential across the orifice meter. Turndown of the air flow will result in a proportional change in the output oil pressure.

The 6 PCR upper diaphragm is connected across a POP Orifice Flow Meter (Bulletin 5720) with the top of the upper diaphragm connected to the upstream side of the POP. The top of the lower diaphragm is normally vented to atmosphere. A static air pressure line runs from the 1/2" NPT tap in the bleed orifice on the 6 PCR outlet to the BZR or the OAR.

The air pressure required at the inlet of the 6 PCR must be 3.6" to 5.2" W.C. higher than the POP maximum pressure differential times 2.5. Example: *if the POP pressure differential is 10" W.C., $[(10 \times 2.5) + 5.2 = 30.2" \text{ W.C.}]$ is the air pressure required at the 6 PCR inlet.*

The 6 PCR holds a constant air/fuel ratio from cold start-up through hot air operation. All control components are on the cold side of the system and are unaffected by high combustion air temperatures, minimizing cost and maintenance and permitting initial start-up adjustment to be made on cold air at the high fire condition and adjusting fuel to the desired ratio.

These regulators are available in the size shown only (i.e. 6 PCR).



FEATURES

- Operating temperatures to 150 °F
- Maximum inlet pressure: 2 psig
- Maximum air signal: 15" W.C.
- Nominal air signal: 10" W.C.
- Minimum air signal: 0.1" W.C.
- 2.5 multiplying factor
- Accuracy:
 - Low Flow: +0.0 / - .05" W.C.
 - Full Flow: +.15 / - 0.2" W.C.
- Turndown: up to 10:1
- All units factory tested and sealed before shipment.

APPLICATIONS

- Hot air burner systems: cover annealing furnaces - reheat furnaces - continuous kilns - glass tanks - etc.
- Varying back pressure systems: paper drying - atmosphere generators - periodic kilns - forced air dryers - lumber kilns

CAUTION: Operation of combustion equipment can be hazardous resulting in bodily injury or equipment damage. Each burner should be supervised by a combustion safeguard and only qualified personnel should install, make system adjustments and perform any required service.



ORDAN THERMAL PRODUCTS LTD
Combustion Equipment & Controls for Industry
21 Amber St # 9, Markham Ontario Canada L3R 4Z3
Tel: (905) 475-9292 Fax: (905) 475-3286
www.ordanthermal.com

NOTICE: PYRONICS practices a policy of continuous improvement in the design of its products. It reserves the right to change the specifications at any time without prior notice.

REGULATORS PILOT CONTROL GAS / OIL

BULLETIN 5107
PAGE NO.2

PCR SYSTEM DIAGRAM

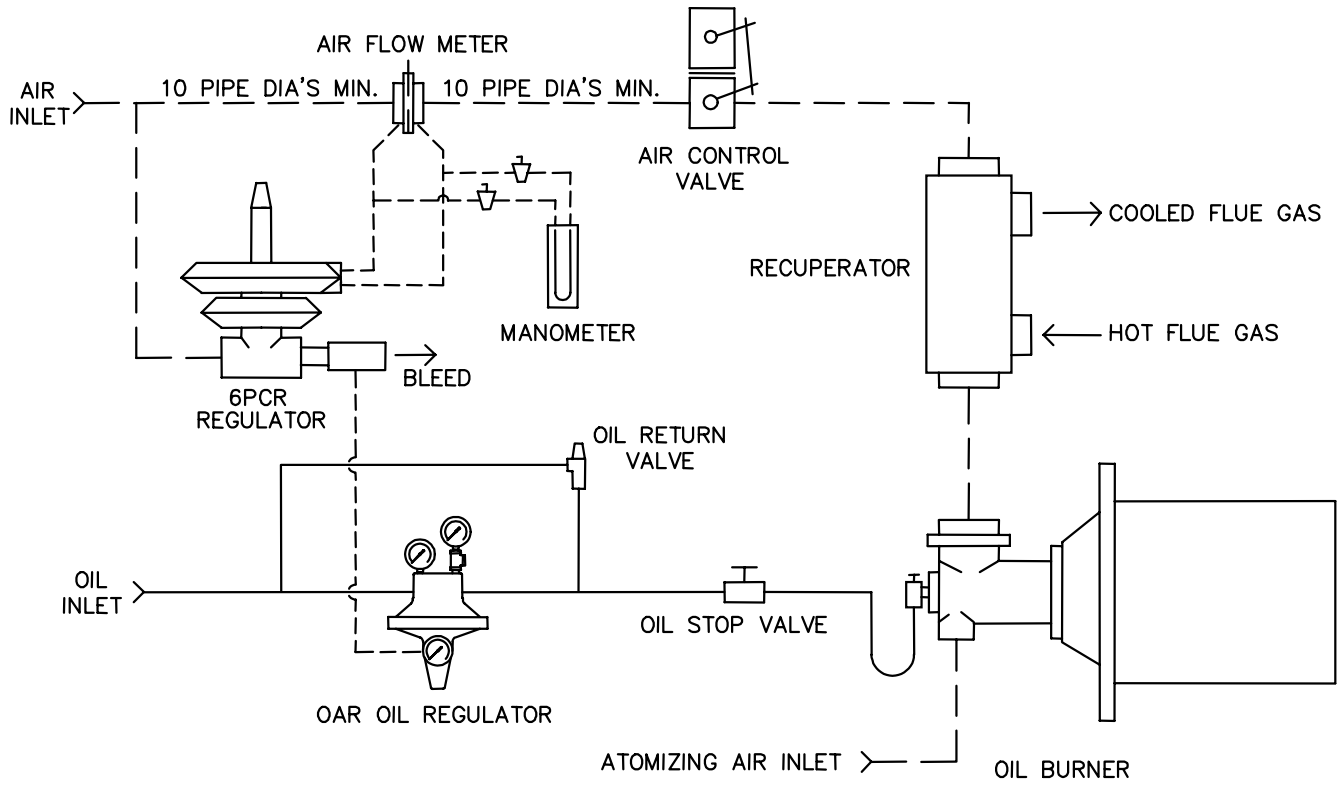

REGULATORS PILOT CONTROL GAS / OIL

BULLETIN 5107
PAGE NO.3

DIMENSIONS

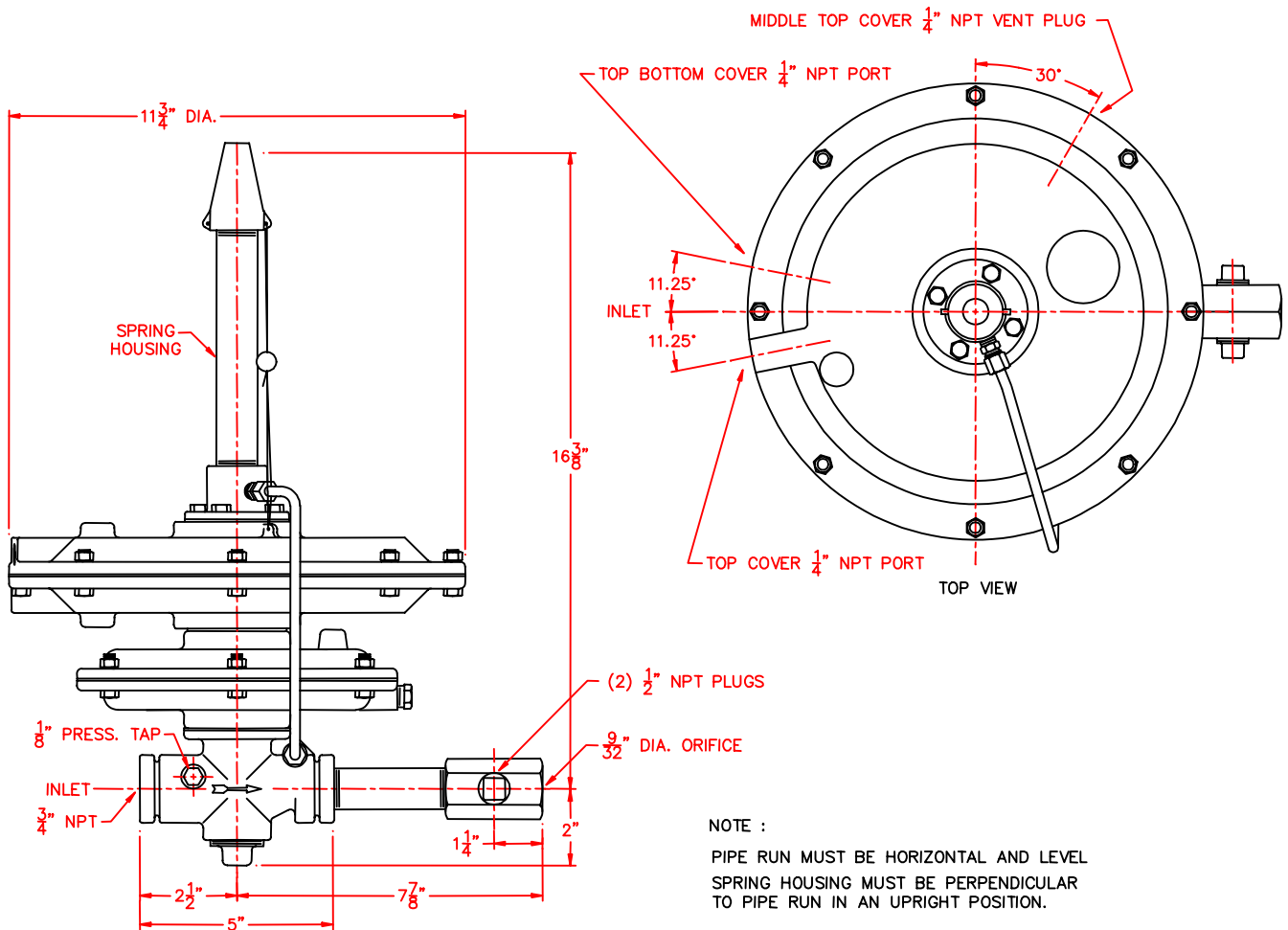

ORDERING INFORMATION

1. Specify Inlet Pressure.
2. Specify Model Number and Quantity.
3. Shipping Instructions.

CAUTION: Operation of combustion equipment can be hazardous resulting in bodily injury or equipment damage. Each burner should be supervised by a combustion safeguard and only qualified personnel should install, make system adjustments and perform any required service.



ORDAN THERMAL PRODUCTS LTD
Combustion Equipment & Controls for Industry
21 Amber St # 9, Markham Ontario Canada L3R 4Z3
Tel: (905) 475-9292 Fax: (905) 475-3286
www.ordanthermal.com

NOTICE: PYRONICS practices a policy of continuous improvement in the design of its products. It reserves the right to change the specifications at any time without prior notice.