

# REGULATORS REDUCING

**MODEL:** 5201-SR, 5202-SR-PC,  
5211-SR-300,  
5212-SR-PC-300

Revision: 1

**BULLETIN**  
5201, 5202  
5211, 5212

## DESCRIPTION

The **SR Series Pressure Reducing Regulator** is designed for industrial furnaces and heating applications. These regulators will maintain a constant outlet pressure over a wide range of flows even if the inlet pressure varies.

Several spring ranges are available, from 4" w.c. to 3 psig. Pilot loaded regulators, the SR-PC series, are also available for higher pressures and flows.

Standard construction is for clean fuel gases including Natural Gas, Propane, Butane and other Hydrocarbon fuels. Special construction is available for gases such as Coke Oven Gas.

The standard model is limited to fluids at temperatures of 150 °F. Special models are available for temperatures to 700 °F.

The standard design has internal compensation. For capacities greater than listed in the table the regulator can be supplied with external compensation.



## CAPACITY TABLE

Model Number	Pipe Size	SCFH Gas Flow @ 14.0" W.C. Pressure Drop			
		MFD.	NAT.	AIR	L.P.
		0.4 Sp. Gr.	0.6 Sp. Gr.	1.0 Sp. Gr.	1.5 Sp. Gr.
SR6 -	3/4"	1,230	1,000	780	630
SR8 -	1"	2,500	2,000	1,500	1,200
SR12 -	1-1/2"	4,900	4,000	3,100	2,500
SR16 -	2"	9,400	7,700	6,000	4,900
SR20 -	2-1/2"	12,300	10,000	7,800	6,300
SR24 -	3"	21,000	17,000	13,000	11,000

Maximum capacity must be limited to less than 200% of ratings above.

These regulators are not suitable for dead-end lockup service. The pressure downstream of these regulators can reach line pressure after extended idle periods. They are capable of controlling pressure at extremely low flows but should not be used as a line gas pressure regulator unless automatic control valve can open against line pressure or a relief regulator is installed immediately downstream.

## FEATURES

- Precision outlet pressure control
- Wide flow range
- Soft valve seating
- Balance valve design - holds outlet pressure constant with varying inlet pressures
- Inlet pressures to 25 psig
- Synthetic, reinforced diaphragms - good for most fuel gases
- Springs color coded for identification

**CAUTION:** Operation of combustion equipment can be hazardous resulting in bodily injury or equipment damage. Each burner should be supervised by a combustion safeguard and only qualified personnel should install, make system adjustments and perform any required service.



**ORDAN THERMAL PRODUCTS LTD**  
Combustion Equipment & Controls for Industry  
21 Amber St # 9, Markham Ontario Canada L3R 4Z3  
Tel: (905) 475-9292 Fax: (905) 475-3286  
[www.ordanthermal.com](http://www.ordanthermal.com)

**NOTICE:** PYRONICS practices a policy of continuous improvement in the design of its products. It reserves the right to change the specifications at any time without prior notice.

# REGULATORS REDUCING

BULLETIN  
5201, 5202,  
5211, 5212  
PAGE NO.2

## OPERATION

### SR REGULATOR

The SR Series Reducing Regulators operate with inlet pressures in the range of 1 psig to 25 psig and delivery pressures from 2" w.c. to 5 psig. The upper diaphragm chamber is normally open to atmosphere while the lower diaphragm chamber, by means of the impulse connection, is subject to outlet pressure.

The seal diaphragm is designed so that its area equals the effective area of the valve disc. Fluctuations in inlet pressure are thus counter-balanced by these two equal areas.

A compression spring loads the main diaphragm with an adjustable force which places the valve in an open position. When the outlet pressure under the main diaphragm equals the spring load, a balance of forces occurs to move the diaphragm and the valve assembly towards the closed position and maintain a constant delivery pressure.

As changes in flow are required by the connected system, there will be slight changes in the outlet pressure and a minor unbalance in forces on the main diaphragm. This large sensitive diaphragm will move either up or down, as required to restore the force balance.

The flow across the patented compensator produces a velocity condition which is proportional to flow. The impulse when combined with the outlet pressure is transmitted to the lower diaphragm chamber and automatically adjusts the valve to hold a constant delivery pressure.

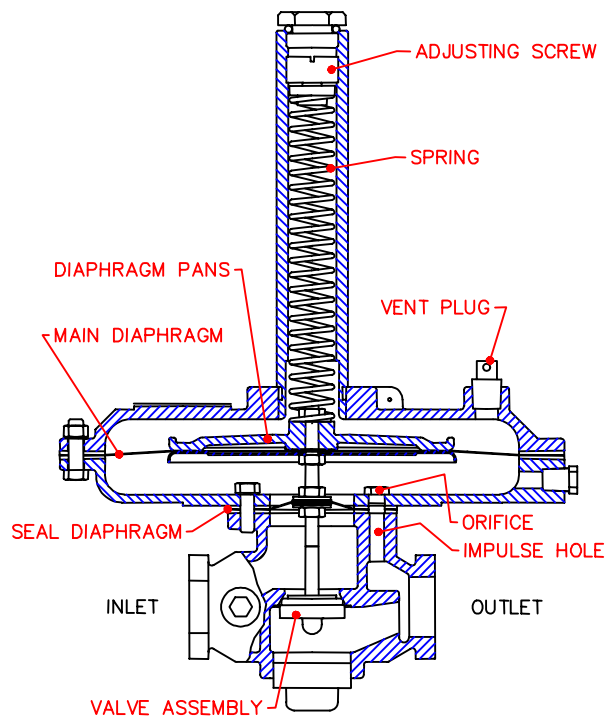

### SR-PC REGULATOR

The larger size Reducing Regulators, with 48 osi spring, SR-20-PC and SR-24-PC (2-1/2" through 3") and with 80 osi spring SR-12-PC through SR-24-PC (1-1/2" through 3"), have very large main diaphragm areas which make spring loading above 16 osi (1 psig) impractical. The 48 osi (white spring) and 80 osi (blue spring) ranges of outlet pressure on these sizes are obtained by pilot loading the main regulator with system gas. An SR 6-48 or 80 Reducing Regulator is connected so that its outlet pressure is applied to the upper diaphragm chamber of the main regulator. A constant flow limiting orifice permits a flow of 50 to 100 SCFH through the pilot regulator.

The force balance required on the main regulator diaphragm is maintained between the top loading pressure (the outlet pressure of the pilot regulator) and the system delivery pressure. The outlet compensator operates in the same manner as the standard spring loaded units.

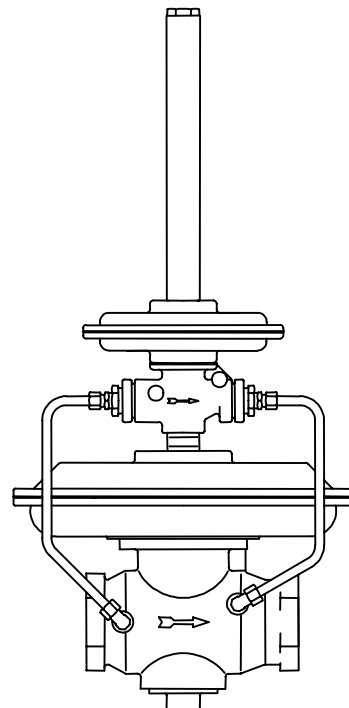

# REGULATORS REDUCING

BULLETIN  
5201, 5202,  
5211, 5212  
PAGE NO.3

## SPRING RANGES - SR and SR-300

Spring Number	Spring Color	Outlet Pressure Range	
		Minimum	Maximum
4	Red	2" w.c. to 8" w.c.	
16	Orange	7" w.c. to 30" w.c.	
48	White	12 osi to 48 osi	
80	Blue	30 osi to 80 osi	

Select spring for each regulator based on required system delivery pressure. Minimum pressure drop across regulator 14" w.c. (1/2 psig).

### SR SERIES W/ 4 OSI SPRING W/ 16 OSI SPRING

Model Number
SR- 6-
SR- 8-
SR-12-
SR-16-
SR-20-
SR-24-

### SR SERIES W/ 48 OSI SPRING

Model Number
SR- 6-
SR- 8-
SR-12-
SR-16-

### SR-PC SERIES W/ 48 OSI SPRING

Model Number
SR-20-PC-
SR-24-PC-

### SR SERIES W/ 80 OSI SPRING

Model Number
SR- 6-
SR- 8-

### SR-PC SERIES W/ 80 OSI SPRING

Model Number
SR-12-PC-
SR-20-PC-
SR-24-PC-

CAUTION: Operation of combustion equipment can be hazardous resulting in bodily injury or equipment damage. Each burner should be supervised by a combustion safeguard and only qualified personnel should install, make system adjustments and perform any required service.



**ORDAN THERMAL PRODUCTS LTD**  
Combustion Equipment & Controls for Industry  
21 Amber St # 9, Markham Ontario Canada L3R 4Z3  
Tel: (905) 475-9292 Fax: (905) 475-3286  
[www.ordanthermal.com](http://www.ordanthermal.com)

NOTICE: PYRONICS practices a policy of continuous improvement in the design of its products. It reserves the right to change the specifications at any time without prior notice.

# REGULATORS REDUCING

BULLETIN  
5201, 5202,  
5211, 5212  
PAGE NO. 4

## INSTALLATION

Regulators must always be mounted in a stem-up position, in a horizontal line, as close as practical to flow control point. Any other mounting position will cause a malfunction. The arrow cast on the side of the valve body indicates direction of flow.

Regulators should not be installed in areas where operating temperatures will exceed 150 °F. Where this requirement results in excessive piping, Remote Compensators should be used. Special high temperature (up to 700 °F) regulators are available where this is not practical.

Outlet piping should be at least the same size as the regulator connection. At least five (5) diameters of straight pipe must be allowed between the regulator and the first downstream valve or fitting. Approved pipe joint compound should be used on all connections to prevent leaks. Piping should be supported, as required. A pipe Flange Pair (see Bulletin 5701) or union may be installed on both sides of Reducing Regulators to simplify replace-

ment should repairs ever become necessary.

**All gas lines should be tested for leaks before operation. When pressure testing lines, remove regulators and cap the lines.**

The top diaphragm cover has a tapped hole for a factory installed bleed vent plug or loading tube connection. Do not install a solid pipe plug in this connection. Obstruction can cause faulty or sluggish operation. Venting of the top diaphragm chamber may be required (check local piping codes). Vent piping, if installed, must be without traps and preferable pitched away from the regulator and protected against stoppage.

Outlet pressure of regulator is dependent on spring compression. Adjustment screw is under stem cap. With a pressure gauge installed in outlet pipe, position slotted spring adjustment plug for desired pressure. Screw down (into housing) to raise pressure and up (out of housing) to lower pressure.

## DIMENSIONS: 3/4" - 3" SR and SR-300

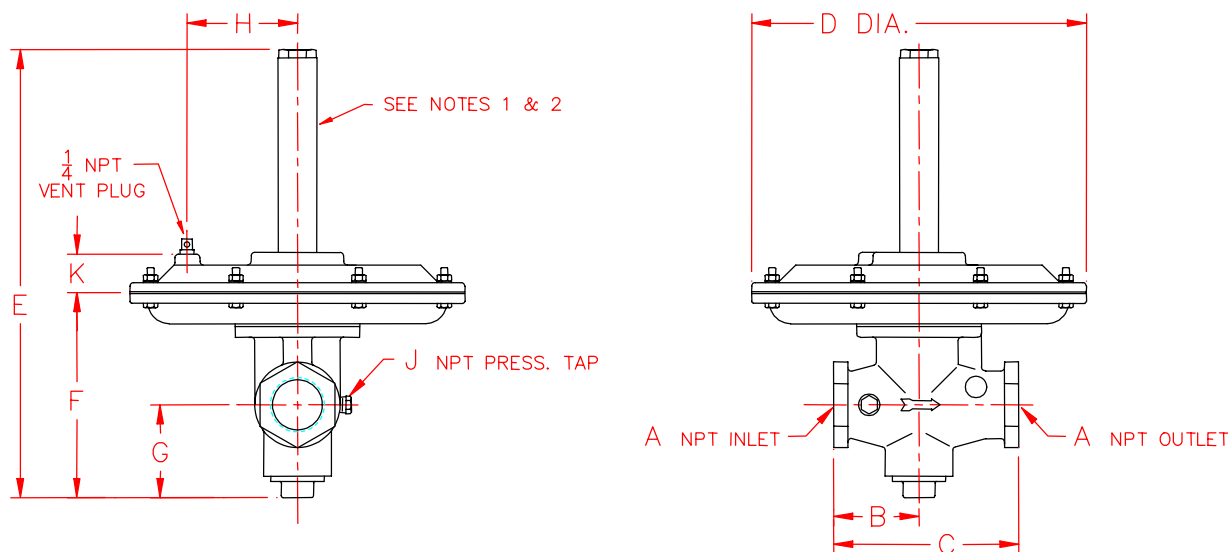

Model Number	A	B	C	D	E	F	G	H	J	K	Weight	
											Lbs.	Kgs.
SR- 6-4, 16, & 48	3/4	2-1/2	5	8-1/4	13-1/4	4-7/8	2	----	1/8	----	8.0	3.63
SR- 6-80	3/4	2-1/2	5	8-1/4	18-1/8	4-7/8	2	----	1/8	----	9.0	4.10
SR- 8-4, 16, & 48	1	2-3/8	4-3/4	9-3/4	13-1/4	4-3/4	2	3-3/8	1/8	1-1/4	9.9	4.50
SR- 8-80	1	2-3/8	4-3/4	9-3/4	16-1/4	4-3/4	2	3-3/8	1/8	1-1/4	11.2	5.10
SR-12-4 & 16	1-1/2	3	6-1/2	11-3/4	15-3/4	7-1/4	3-1/4	3-7/8	1/4	1-3/8	16.1	7.35
SR-12-48	1-1/2	3	6-1/2	9-3/4	15-1/2	7	3-1/4	3-3/8	1/4	1-1/4	14.1	6.40
SR-16-4, 16, & 48	2	3-1/2	7-1/2	9-3/4	16-3/8	8	3-7/8	3-3/8	1/4	1-1/4	18.0	8.18
SR-20-4 & 16	2-1/2	4	8-3/4	14	20-7/8	8-3/4	3-5/8	3-5/8	1/4	1-7/8	52.8	24.00
SR-24-4 & 16	3	5-3/4	11-1/2	14	22-5/8	10-5/8	4-5/8	3-5/8	1/4	1-7/8	63.8	29.00

### NOTES:

1. Spring housing must be perpendicular to pipe run in an upright position.
2. Gas pipe run must be horizontal and level.
3. All dimensions are in inches.

# REGULATORS REDUCING

BULLETIN  
5201, 5202,  
5211, 5212  
PAGE NO.5

## DIMENSIONS: 1-1/2" - 3" SR-PC and SR-PC-300

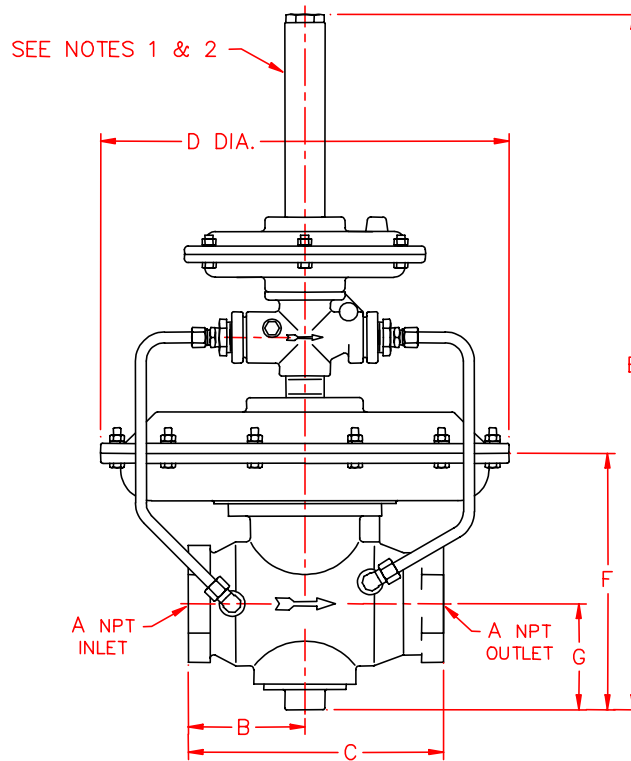

Model Number	A	B	C	D	E	F	G	Weight	
								Lbs.	Kgs.
SR-12-PC-80	1-1/2	3	6-1/2	11-3/4	26-7/8	7-1/4	3-1/4	24.4	11.1
SR-20-PC-48	2-1/2	4	8-3/4	14	24	8-3/4	3-5/8	55.0	25.0
SR-20-PC-80	2-1/2	4	8-3/4	14	28-7/8	8-3/4	3-5/8	57.2	26.0
SR-24-PC-48	3	5-3/4	11-1/2	14	25-7/8	10-5/8	4-5/8	72.6	33.0
SR-24-PC-80	3	5-3/4	11-1/2	14	30-3/4	10-5/8	4-5/8	74.4	33.8

### NOTES:

1. Spring housing must be perpendicular to pipe run in an upright position.
2. Gas pipe run must be horizontal and level.
3. All dimensions are in inches.

## ORDERING INFORMATION

1. Specify Model Number and quantities of Reducing Regulators required from capacity table on Page 1.
2. Select spring ranges required from table on Page 3.
3. Add code letters "RC" for Remote Compensator feature including compensator. Regulators for this use must be special assembled at factory.
4. Examples: #SR8-16-RC Reducing Regulator for a 7" to 30" w.c. adjustable outlet range, 1" size unit complete with Remote Compensator.
5. If in doubt about selection, send full information on operating requirements, flows, inlet and outlet pressures, type of gas, temperature, etc. for rapid determination by factory application engineers or contact your nearest Pyronics representative.

CAUTION: Operation of combustion equipment can be hazardous resulting in bodily injury or equipment damage. Each burner should be supervised by a combustion safeguard and only qualified personnel should install, make system adjustments and perform any required service.



**ORDAN THERMAL PRODUCTS LTD**  
Combustion Equipment & Controls for Industry  
21 Amber St # 9, Markham Ontario Canada L3R 4Z3  
Tel: (905) 475-9292 Fax: (905) 475-3286  
www.ordanthermal.com

NOTICE: PYRONICS practices a policy of continuous improvement in the design of its products. It reserves the right to change the specifications at any time without prior notice.