

REGULATORS SPRING BIASED

MODEL: 5106-BZR-B

Revision: 0

BULLETIN
5106

DESCRIPTION

BZR-B is designed with an adjustable compensation spring to bias the regulator providing a smooth transition to excess air operation at low fire. Using a gas adjuster downstream of a negative biased regulator, high fire can be set to stoichiometric conditions. As the system is turned down, the spring bias will subtract from the combustion air pressure causing the burner to go lean. Adjusting the screw under the cap assembly permits biasing the fuel/air ratio from high fire to low fire at a fixed, controlled rate.

As shipped, the regulator is set at zero bias.

For installation, see Bulletin 5101 Installation.

CAPACITY TABLE

| Model Number | Pipe Size | | SCFH Gas Flow @ 4.0" W.C. Pressure Drop | | | |
|--------------|-----------|--------|---|---------------------|--------------------|---------------------|
| | Inlet | Outlet | MFD. 0.4 Sp. Gr. | NAT. 0.6 Sp. Gr. | AIR 1.0 Sp. Gr. | L.P. 1.5 Sp. Gr. |
| 6-BZR-B | 3/4" | 3/4" | 790 | 650 | 500 | 410 |
| 8-BZR-B | 1" | 1" | 1,580 | 1,290 | 1,000 | 820 |
| 12-BZR-B | 1-1/2" | 1-1/2" | 3,160 | 2,580 | 2,000 | 1,640 |
| 16-BZR-B | 2" | 2" | 5,530 | 4,520 | 3,500 | 2,860 |
| 20-BZR-B | 2-1/2" | 2-1/2" | 7,900 | 6,450 | 5,000 | 4,100 |
| 24-BZR-B | 3" | 3" | 12,600 | 10,300 | 8,000 | 6,500 |
| 32-BZR-B | 4" | 4" | 22,100 | 18,100 | 14,000 | 11,400 |



FEATURES

- Accuracy:
 - Low - Flow: ± 0.1 " W.C.
 - Full - Flow: ± 0.3 " W.C.
- Turndown up to 20:1
- Continuous operation to 150 °F
- All units factory tested and sealed before shipment
- Maximum inlet pressure: 2.0 psig
- Minimum pressure drop through regulator: 4.0" W.C.
- Sensitivity - Responds to signal pressure differential as low as 0.04" W.C.
- Adjustable spring bias from:
 - + 0.3/-5.0" W.C.

CAUTION: Operation of combustion equipment can be hazardous resulting in bodily injury or equipment damage. Each burner should be supervised by a combustion safeguard and only qualified personnel should install, make system adjustments and perform any required service.



ORDAN THERMAL PRODUCTS LTD
 Combustion Equipment & Controls for Industry
 21 Amber St # 9, Markham Ontario Canada L3R 4Z3
 Tel: (905) 475-9292 Fax: (905) 475-3286
www.ordanthermal.com

NOTICE: PYRONICS practices a policy of continuous improvement in the design of its products. It reserves the right to change the specifications at any time without prior notice.

REGULATORS SPRING BIASED

BULLETIN 5106
PAGE NO. 2

DIMENSIONS: 3/4" - 3" SIZES

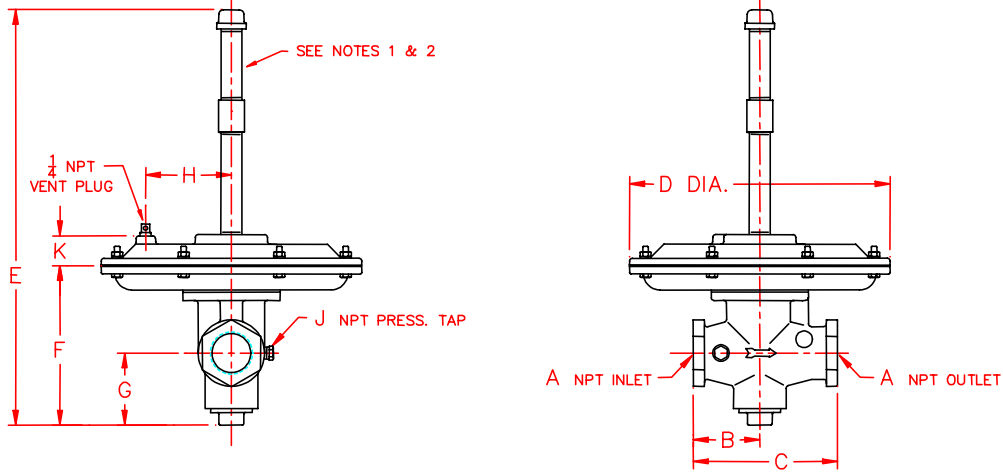

| Model Number | A | B | C | D | E | F | G | H | K | Weight | |
|--------------|-------|-------|--------|--------|--------|--------|-------|-------|-------|--------|-------|
| | | | | | | | | | | Lbs. | Kgs. |
| 6-BZR-B | 3/4 | 2-1/2 | 5 | 8-1/4 | 20-3/4 | 4-7/8 | 2 | ----- | ----- | 7.0 | 3.17 |
| 8-BZR-B | 1 | 2-3/8 | 4-3/4 | 9-3/4 | 24 | 4-3/4 | 2 | 3-3/8 | 1-1/4 | 9.0 | 4.07 |
| 12-BZR-B | 1-1/2 | 3 | 6-1/2 | 11-3/4 | 26-1/2 | 7-1/4 | 3-1/4 | 3-7/8 | 1-3/8 | 16.0 | 7.25 |
| 16-BZR-B | 2 | 3-1/2 | 7-1/2 | 11-3/4 | 30-7/8 | 8-1/8 | 3-7/8 | 3-7/8 | 1-3/8 | 21.0 | 9.52 |
| 20-BZR-B | 2-1/2 | 4 | 8-3/4 | 14 | 31-1/8 | 8-3/4 | 3-5/8 | 3-5/8 | 1-7/8 | 51.0 | 23.13 |
| 24-BZR-B | 3 | 5-3/4 | 11-1/2 | 14 | 35-3/8 | 10-5/8 | 4-5/8 | 3-5/8 | 1-7/8 | 61.0 | 27.66 |

DIMENSIONS: 4" SIZE

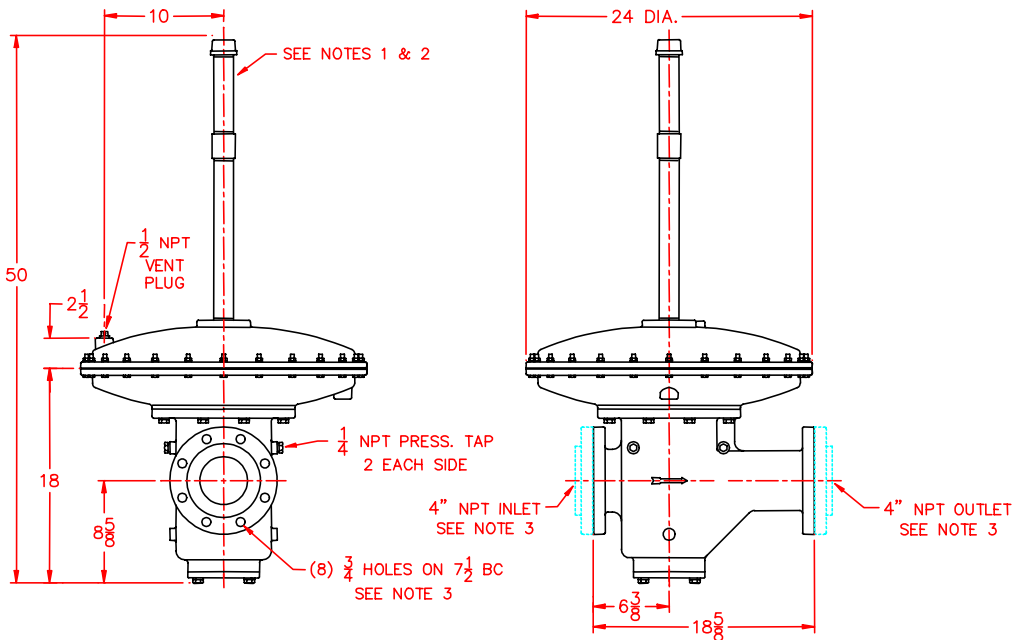

WEIGHT 182 LBS

NOTES:

- | | |
|--|---|
| <ol style="list-style-type: none"> 1. Spring housing must be perpendicular to pipe run in an upright position. 2. Gas pipe run must be horizontal and level. | <ol style="list-style-type: none"> 3. Designed to accept standard 4" ANSI flanges. 4. All dimensions are in inches. |
|--|---|

ORDERING INFORMATION

- | | |
|--|--|
| <ol style="list-style-type: none"> 1. Specify Inlet and Outlet Pressure. 2. Type of Gas, Flow, Specific Gravity and Temperature. | <ol style="list-style-type: none"> 3. Specify Model Number and Quantity. 4. Shipping Instructions. |
|--|--|

REGULATORS SPRING BIASED

BULLETIN 5106
PAGE NO.3

SETTING THE BZR-B BIAS AIR RATE AT LOW FIRE

1. With the furnace firing and hot, cycle the combustion system to low fire following the steps in the manufacturer's operating instructions. Carefully monitor the burners to insure they do not extinguish. Remove the cap assembly (item 1).
2. If possible, take an oxygen reading of the flue gas. If more oxygen is needed, turn the locknuts (item 2) clockwise to increase spring tension and decrease gas flow. After each adjustment on the locknuts the cap assembly (item 1) must be replaced to prevent leakage of the air impulse pressure.
3. Return to high fire and reset the adjustable orifice valve for the proper gas flow at this firing rate.
4. Return to low fire and repeat the procedure in steps 1, 2, and 3 as many times as is necessary to achieve the oxygen level desired.
5. Once the oxygen level is reached, tighten the locknuts (item 2) to each other and install the cap assembly (item 1) with a pipe wrench. DO NOT overtighten.

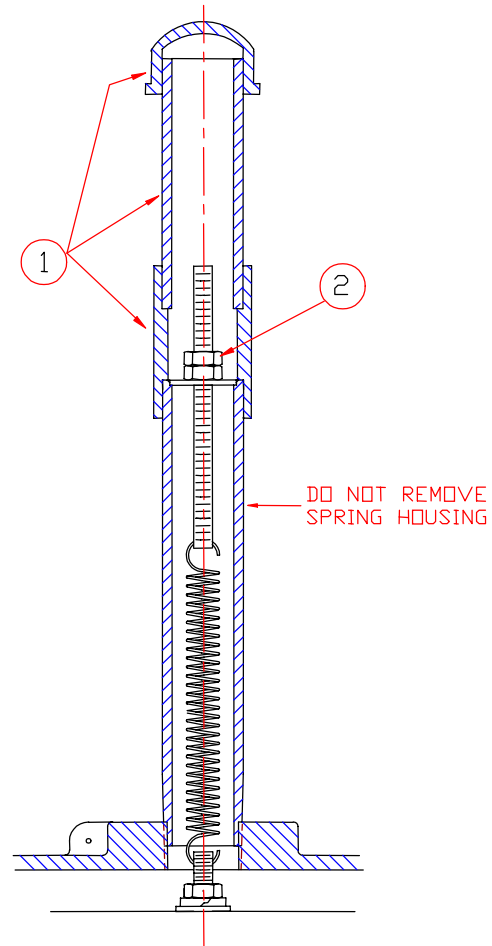

CAUTION: Operation of combustion equipment can be hazardous resulting in bodily injury or equipment damage. Each burner should be supervised by a combustion safeguard and only qualified personnel should install, make system adjustments and perform any required service.



ORDAN THERMAL PRODUCTS LTD
Combustion Equipment & Controls for Industry
21 Amber St # 9, Markham Ontario Canada L3R 4Z3
Tel: (905) 475-9292 Fax: (905) 475-3286
www.ordanthermal.com

NOTICE: PYRONICS practices a policy of continuous improvement in the design of its products. It reserves the right to change the specifications at any time without prior notice.