

BLAST GATES THREADED

MODEL: 1381 - AV - T

Revision: 0

BULLETIN
1381

DESCRIPTION

Pull Handle blast gates are low cost, rugged valves used for manual air flow control on combustion systems. These units are designed for air pressures up to 5 psig or low pressure air up to 600 °F.

The slides on all size blast gates are stainless steel. Slides are swivel mounted on shafts – a tamper-proof assembly. Shaft can be rotated without damaging the gate. The slide is precision mounted between accurately machined flanges for smooth and easy operation. Stem packing gland is provided for “leak-resistant” construction.

All gates are equipped with an adjustable thumb screw lock to prevent movement from vibration. They are also available with an optional minimum stop.

Threaded connection blast gates are available in sizes from 1” to 6”.



APPLICATIONS

- Low Pressure Air Control
- Viewing Ports with Peepsights
- Fixed By-Pass Orifices
- Gravity Fed Feedstock Control
- Fertilizer Distribution
- Granular Glaze Distribution
- Manual Stack Pressure Control

FEATURES

- Stainless steel gates are standard for all sizes.
- Swivel mounted gate and shaft assembly.
- Thumb screw shaft locks.
- Free floating gate -- will not bind.
- Cast iron construction.
- Available with minimum stop arrangement.

CAUTION: Operation of combustion equipment can be hazardous resulting in bodily injury or equipment damage. Each burner should be supervised by a combustion safeguard and only qualified personnel should install, make system adjustments and perform any required service.



ORDAN THERMAL PRODUCTS LTD
Combustion Equipment & Controls for Industry
21 Amber St # 9, Markham Ontario Canada L3R 4Z3
Tel: (905) 475-9292 Fax: (905) 475-3286
www.ordanthermal.com

NOTICE: PYRONICS practices a policy of continuous improvement in the design of its products. It reserves the right to change the specifications at any time without prior notice.

BLAST GATES THREADED

BULLETIN 1381
PAGE NO. 2

DIMENSIONS

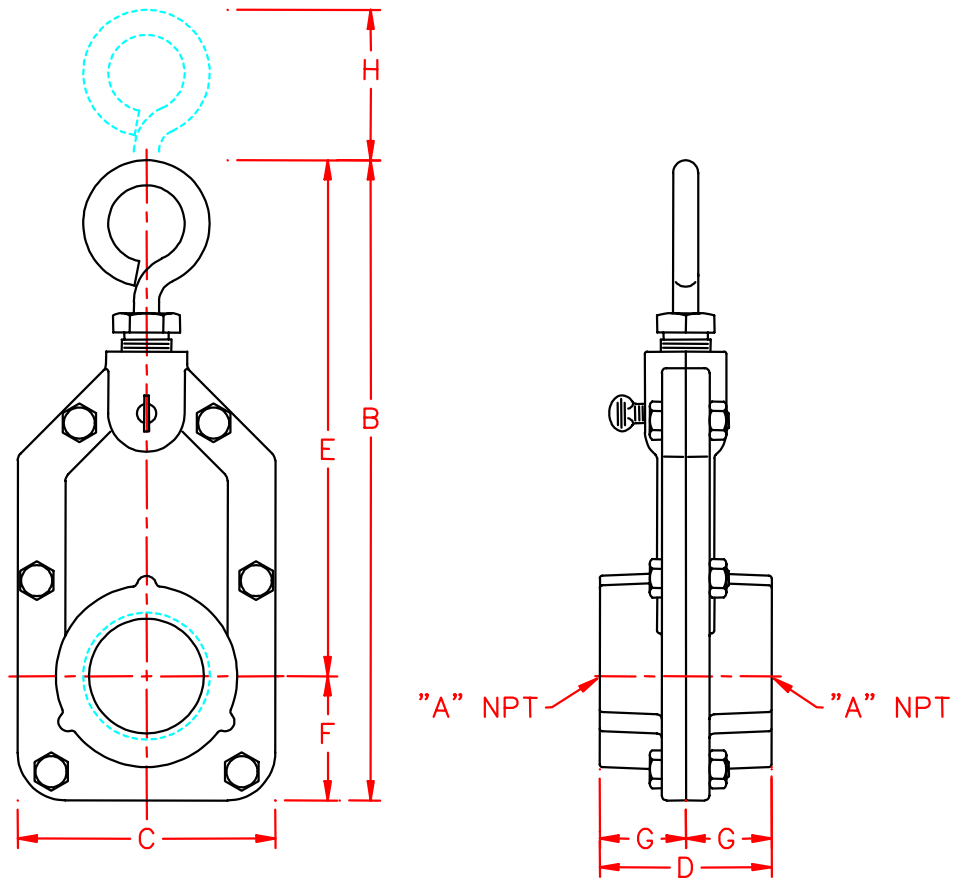

Model Number	A	B	C	D	E	F	G	H	Weight	
									Lbs.	Kgs.
8 AV-T	1	8-3/8	3-3/8	2-1/4	6-3/4	1-5/8	1-1/8	1-7/8	4.3	1.95
10 AV-T	1-1/4	8-3/8	3-3/8	2-1/4	6-3/4	1-5/8	1-1/8	1-7/8	4.1	1.86
12 AV-T	1-1/2	8-3/8	3-3/8	2-1/4	6-3/4	1-5/8	1-1/8	1-7/8	3.5	1.58
16 AV-T	2	10-1/4	4	3-1/8	8-1/4	2	1-9/16	2-1/4	7.5	3.40
20 AV-T	2-1/2	10-1/4	4	3-1/8	8-1/4	2	1-9/16	2-1/4	6.0	2.72
24 AV-T	3	12-1/2	5-3/4	3-7/8	9-5/8	2-7/8	1-15/16	3-3/4	13.1	5.94
32 AV-T	4	14-1/2	6-1/2	4	11	3-1/2	2	4-1/4	15.2	6.90
48 AV-T	6	18-1/8	9	4-5/8	13-5/8	4-1/2	2-5/16	6-3/8	38.8	17.61

NOTE: All dimensions are in inches.

ORDERING INFORMATION

1. Specify Model Number and Quantity
2. Shipping Instructions